

Technical Information

OCM223/253

Measurement of free chlorine/chlorine dioxide/total chlorine Transmitter for chlorine sensors



Your benefits

- Field or panel-mounted housing
- Universal application
- pH compensation for free chlorine
- Simple handling
 - Logically arranged menu structure
 - Calibration via CAL button
- Safe operation
 - Overvoltage (lightning) protection
 - Direct access for manual contact control
 - User-defined alarm configuration

The basic unit can be extended with:

- 2 or 4 additional contacts for use as:
 - Limit contacts (also for temperature)
 - P(ID) controller for chlorine and pH
 - Timer for simple rinse processes
 - Complete cleaning with Chemoclean
- Plus package:
 - Manual pH compensation for Cl₂
 - Any current output configuration via table
 - Automatic cleaning start
 - Process monitoring
 - Live check of sensor
- HART® or PROFIBUS PA / DP
- 2nd current output for temperature, main measured value or actuating variable
- Current input for flow rate monitoring with controller shut off or for feedforward control

Application

The modular design of the OCM223/253 allows easy adaption of the transmitter to a variety of customer requirements. Starting with the basic version for "measurement and alarm generation", the transmitter can be equipped with additional software and hardware modules for special applications. These modules can also be retrofitted as required.

Application

- Drinking water
- Water treatment
- Cooling water
- Gas scrubbers
- Reverse osmosis
- Food processing
- Swimming pool water

Function and system design

Features of the basic version (EK)

Measurement of free chlorine, chlorine dioxide and total chlorine

The sensor is selected from the menu. The temperature is displayed but the reading can also be hidden. The EP version has an alternative feature that allows simultaneous display of the pH and redox measurements.

Calibration

The OCS140/141 sensors for free chlorine and the OCS240/241 sensors for chlorine dioxide are zero-current-free and therefore require only **single-point calibration**. This is carried out by entering a DPD reference measured value.

The sensor OCS120 is also calibrated by entering a DPD reference measured value. Additionally you can calibrate the zero point of the sensor OCS120 (recommended for measurements below 0.1 mg/l).

Configuration

Different alarms are required depending on application and operator. Therefore the transmitter permits independent **configuration of the alarm contact and error current** for each individual error. Unnecessary or undesirable alarms can be suppressed in this manner. **Up to four contacts** can be used as limit contacts (also for temperature), to implement a P(ID) controller or for cleaning functions.

Direct **manual operation of the contacts** (bypassing the menu) provides quick access to limit, control or cleaning contacts, permitting speedy correction of deviations.

The **serial numbers** of the instrument and modules and the order code can be called up on the display.

Additional functions of the Plus package (ES)

Current output configuration

In order to output wide measuring ranges while still achieving a high resolution in specific ranges, the **current output** can be configured as required via a table. This permits **bilinear** or **quasi-logarithmic** curves, etc.

Manual pH compensation for free chlorine

Measurement of free chlorine with amperometric sensors is pH-dependent while DPD measurement used for calibration is pH-independent. **Manual pH compensation** means the instrument can also be used to measure a variable pH value with a slow rate of change.

Process Check System (PCS)

It comprises two independent safety functions:

- Errors in applications **without** control are detected by monitoring the limit between plausible and implausible measured values, i.e. **the alarm threshold**.
- Errors in applications **with** control are detected by the **controller monitor** which monitors freely adjustable, maximum permissible time intervals and reference value overshoot or undershoot.

Live check

The live check issues an alarm when the sensor signal does not change over a defined period of time. This may be caused by blocking, passivation, separation from the process, etc.

Additional functions of version EP

Alternatively measurement of pH or ORP

This extension allows additional measurement of pH value or ORP in an instrument. It also allows control of the pH value in the process.

Automatic pH compensation means the instrument can also be used to measure a variable pH value which is subject to frequent changes.

Second current output

The second current output is freely configurable for the output of temperature, of the main measured value (free chlorine, chlorine dioxide, total chlorine) or actuating variable.

Current input

The current input of the transmitter allows two different applications: controller shut-down in case of lower flow rate violation or total failure in the main flow as well as feedforward control. Both functions are also combinable.

Explosion proof versions for zone 2

Application of transmitter and sensor in hazardous area zone 2

Field housing OCM253 with power supply 24 V

Application of transmitter as related electrical equipment in non-hazardous area or in simple pressurized apparatus; application of sensor in hazardous area zone 2

Field housing OCM253 with power supply 230 V

or
Panel-mounted housing OCM223 with power supply 230 V or 24 V

Measuring system

A complete measuring system comprises:

Version 1 (free chlorine and chlorine dioxide)

- The transmitter OCM223 or OCM253
- A membrane covered sensor OCS140/141 for Cl₂ or OCS240/241 for ClO₂ or an open sensor 963 for Cl₂
- A flow assembly OCA250 (not necessary for sensor 963)

and optional:

- A pH or ORP sensor
- An INS proximity switch for flow monitoring (omitted with 963 sensor)
- OMK extension cable for chlorine measurement if required
- OYK71 extension cable for pH/ORP measurement if required
- MK extension cable for INS proximity switch if required
- VBC junction box

Version 2 (total chlorine)

- The transmitter OCM223 or OCM253
- A sensor for total chlorine OCS120
- A flow assembly OCA250 or immersion assembly OYA611
- A special measuring cable OPK9, PM wire internally

and optional:

- A pH or ORP sensor
- An INS proximity switch for flow monitoring (omitted with immersion assembly)
- OMK extension cable (PM wire internally) for chlorine measurement if required
- OYK71 extension cable for pH/ORP measurement if required
- MK extension cable for INS proximity switch if required
- VBC junction box

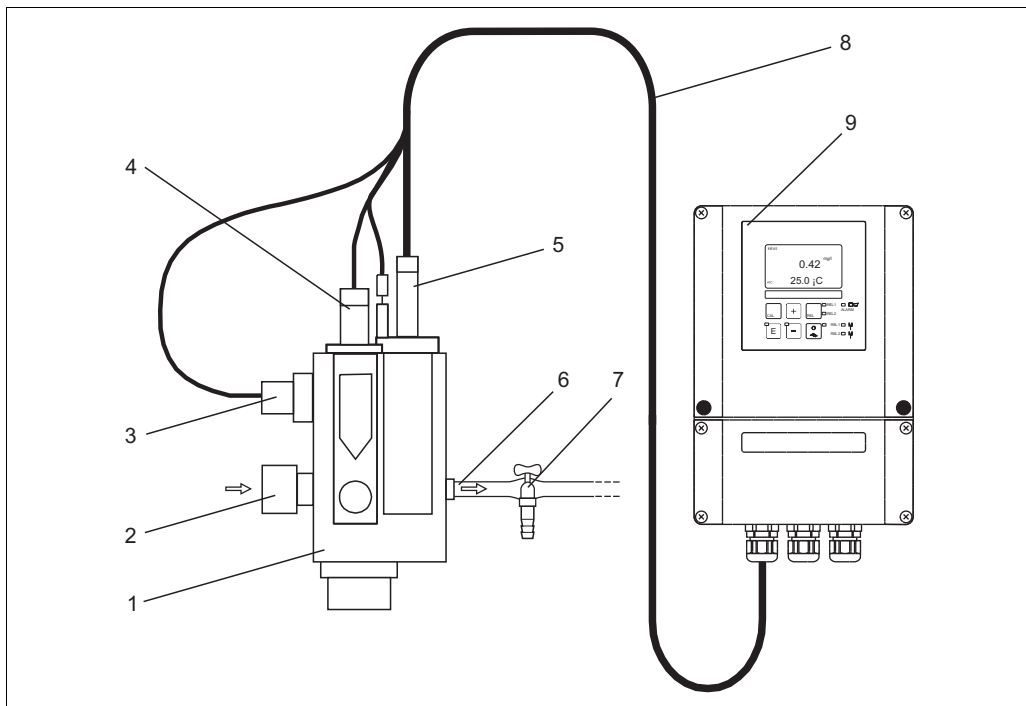

a0001691

Measuring system with flow assembly (example)

- | | | | |
|---|--------------------------------------|---|-----------------|
| 1 | Flow assembly OCA250 | 6 | Medium outlet |
| 2 | Medium inlet | 7 | Sampling tap |
| 3 | Proximity switch for flow monitoring | 8 | Measuring cable |
| 4 | Mounting place for pH/redox sensor | 9 | Transmitter |
| 5 | Chlorine sensor | | |

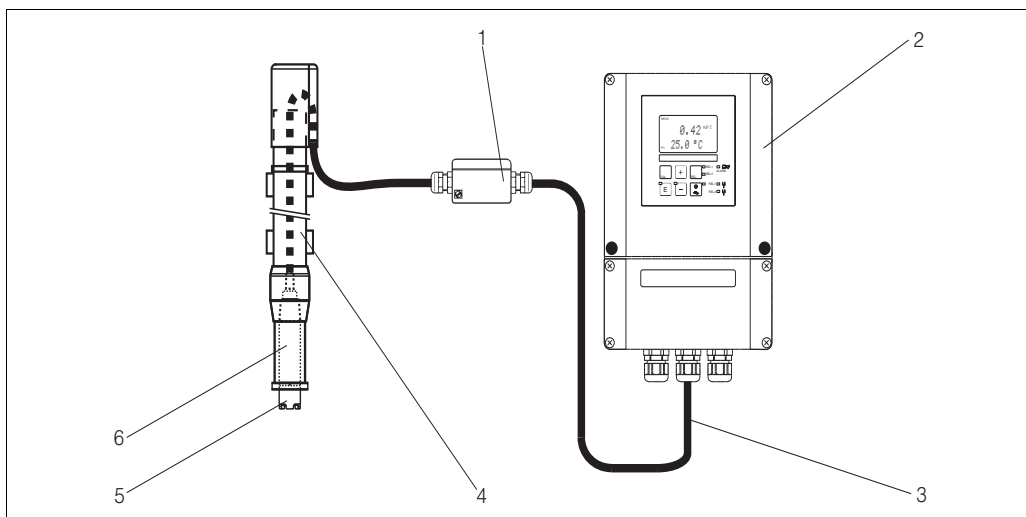

a0001791

Measuring system with immersion assembly (example)

- | | | | |
|---|-----------------|---|---------------------------|
| 1 | Junction box | 4 | Immersion assembly OYA611 |
| 2 | Transmitter | 5 | Chlorine sensor OCS120 |
| 3 | Measuring cable | 6 | Assembly adapter G1 |

Input

Measured variables	Total chlorine, free chlorine, chlorine dioxide, temperature pH or ORP (optional)	
Cl₂/ClO₂ measurement	Display and measuring range	0 to 5 / 0 to 20 mg/l
	Application measuring range	
	OCS120	0.1 to 10 mg/l
	OCS140/240	0.05 to 20 mg/l
	OCS141/241	0.01 to 5 mg/l
	963	0.05 to 5 mg/l
	Temperature compensation range	
	OCS140/240/141/241 and 963	2 to 45 °C (36 to 113 °F)
	OCS120	5 to 45 °C (41 to 113 °F)
	pH compensation range for free chlorine	pH 4 to 9
	Calibration range	pH 4 to 8
	Reference point for nominal slope	25 °C (77 °F) / pH 7.2
Cable specification	Chlorine/chlorine dioxide sensors OCS140/141/240/241:	max. 30 m (98 ft) with CMK cable
	Chlorine sensor 963:	max. 30 m (98 ft) with MK cable
	Total chlorine sensor OCS120:	max. 15 m (49 ft) with CPK9 cable
	pH/ORP measurement:	max. 50 m (164 ft) with CYK71 cable
Cl₂/ClO₂ signal input	OCS120/140/141/240/241:	0 to 5000 nA
	Sensor 963:	-100 to 500 µA
Binary inputs	Voltage:	10 to 50 V
	Power consumption:	max. 10 mA
Current input	4 ... 20 mA, galvanically separated	
	Load: 260 Ω at 20 mA (voltage drop 5.2 V)	

Output

Current range	0/4 to 20 mA, galvanically separated, active	
Error current	2.4 or 22 mA in case of an error	
Load	maximum 500 Ω	
Transmission range	Cl ₂ /ClO ₂ :	0 to 10 mg/l for OCS120 0 to 20 mg/l for OCS140/240 0 to 5 mg/l for OCS141/241 and 963
	Temperature:	0 to 50 °C (32 to 122 °F)
	pH:	pH 4 to 9
	ORP:	0 to 1500 mV
Resolution	max. 700 digits/mA	
Isolation voltage	max. 350 V _{RMS} /500 V DC	
Overvoltage protection	according to EN 61000-4-5	
Auxiliary voltage output	Output voltage:	15 V \pm 0.6
	Output current:	max. 10 mA
Contact outputs	Switching current with ohmic load (cos φ = 1):	max. 2 A
	Switching current with inductive load (cos φ = 0.4):	max. 2 A
	Switching voltage:	max. 250 V AC, 30 V DC
	Switching power with ohmic load (cos φ = 1):	max. 500 VA AC, 60 W DC
	Switching power with inductive load (cos φ = 0.4):	max. 500 VA AC, 60 W DC
Limit contactor	Pickup/dropout delay:	0 to 2000 s
Controller	Function (adjustable):	Pulse-length/pulse-frequency controller, three-point step controller for Cl ₂ /ClO ₂
	Controller response:	P, PI, PD, PID, basic load dosing
	Controller gain K _p :	0.01 to 20.00
	Integral action time T _n :	0.0 to 999.9 min
	Derivative action time T _v :	0.0 to 999.9 min
	Period length of pulse-length controller:	0.5 to 999.9 s
	Frequency for pulse-frequency controller:	60 to 180 min ⁻¹
	Basic load:	0 to 40% of max. set value
	Motor run time for three-point step controller:	10 to 999 s
	Neutral zone for three-point step controller:	0 to 40 %
Alarm	Function (switchable):	Latching/momentary contact
	Alarm threshold adjustment range:	Cl ₂ /ClO ₂ /pH/ORP/temperature: total measuring range
	Alarm delay:	0 to 2000 s (min)
	Monitoring time lower limit violation:	0 to 2000 min
	Monitoring time upper limit violation:	0 to 2000 min

Power supply

Electrical connection variant 1

The wiring diagram shows the connections of the transmitter with all options

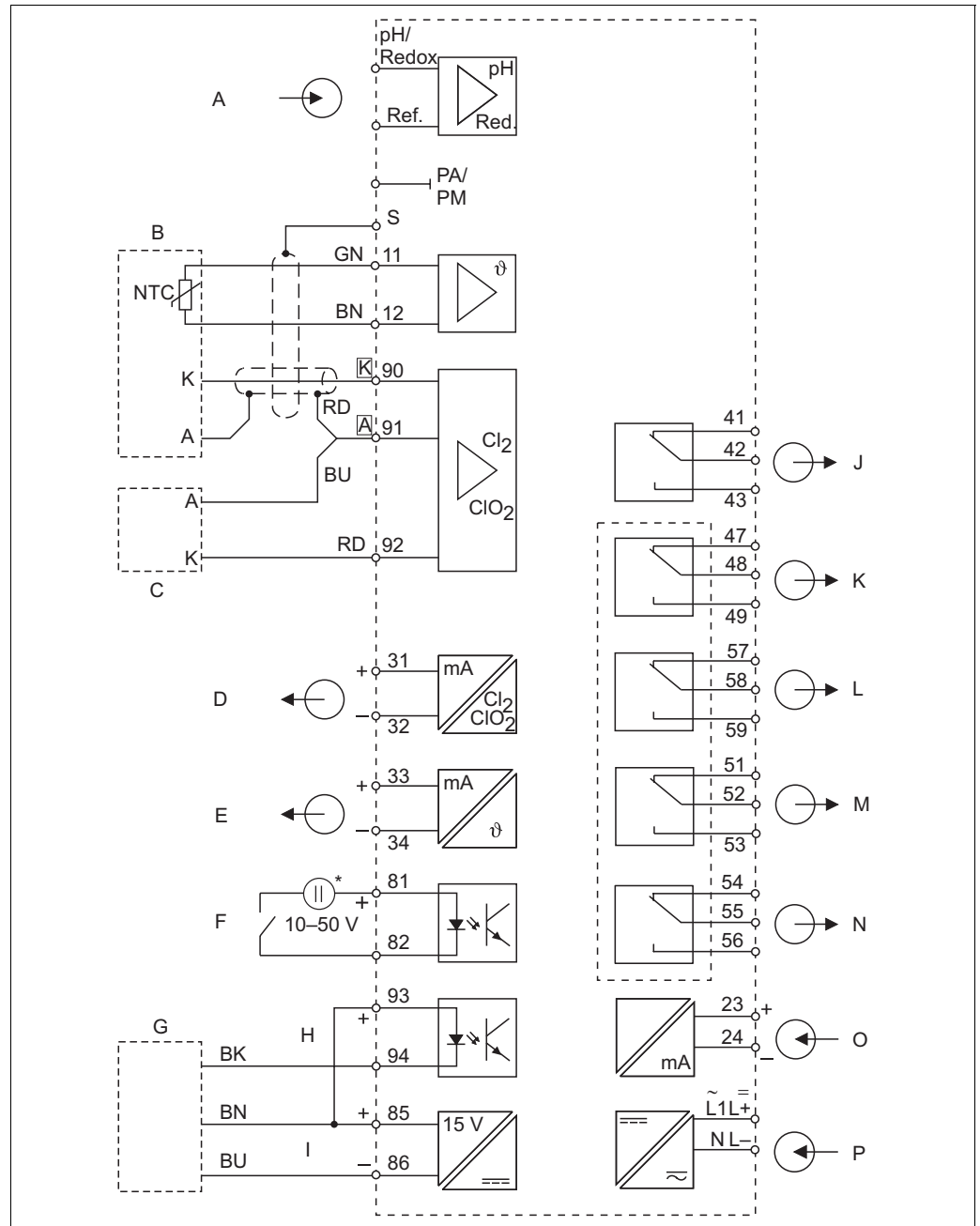

Electrical connection of the transmitter (version 1)

- | | | | |
|---|---|---|---|
| A | pH / ORP input (optional) | I | Aux. voltage output |
| B | Sensor OCS140/141/240/241 | J | Alarm (current-free contact position) |
| C | Sensor 963 (alternative) | K | Relay 1 (current-free contact position) |
| D | Signal output 1 chlorine / chlorine dioxide | L | Relay 2 (current-free contact position) |
| E | Signal output 2 temperature, pH or ORP | M | Relay 3 (current-free contact position) |
| F | Binary input 1 (hold / cleaning) | N | Relay 4 (current-free contact position) |
| G | Proximity switch INS | O | Current input 4 to 20 mA |
| H | Binary input 2 | P | Power supply |
| * | Aux. voltage output terminal 85/86 applicable | | |



Note!

The device is approved for protection class II and is generally operated without protective ground connection.

The circuits "E" and "I" are not galvanically separated from each other.

**Electrical connection
variant 2 (total chlorine)**

The wiring diagram shows the connections of the transmitter with all options

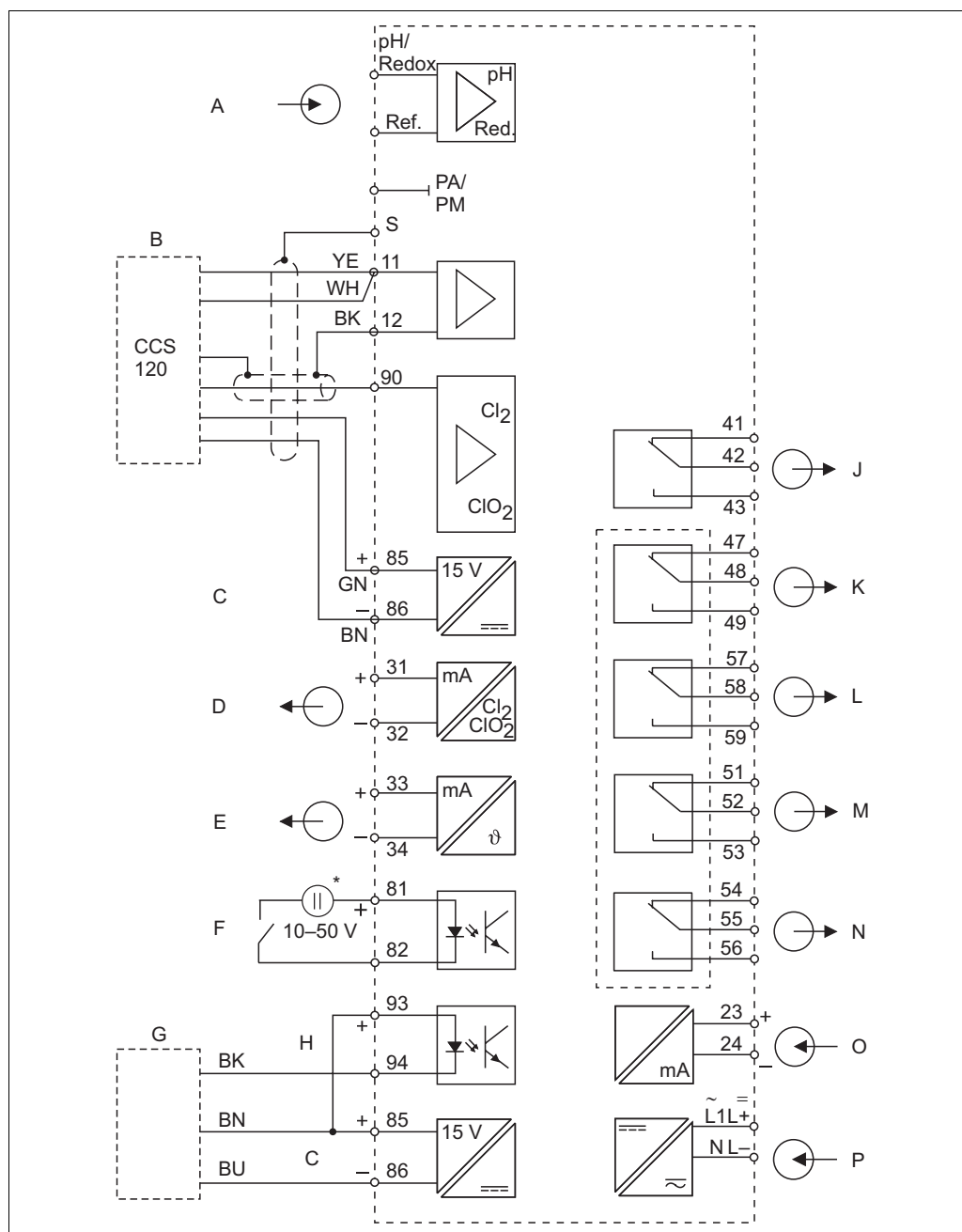

a0001904

Electrical connection of the transmitter (version 2)

A	pH / ORP input (optional)	J	Alarm (current-free contact position)
B	Sensor OCS120	K	Relay 1 (current-free contact position)
C	Aux. voltage output	L	Relay 2 (current-free contact position)
D	Signal output 1 total chlorine	M	Relay 3 (current-free contact position)
E	Signal output 2 temperature, pH or ORP	N	Relay 4 (current-free contact position)
F	Binary input 1 (hold / cleaning)	O	Current input 4 to 20 mA
G	Proximity switch INS	P	Power supply
H	Binary input 2		
*	Aux. voltage output terminal 85/86 applicable		

Note!

The device is approved for protection class II and is generally operated without protective ground connection.

The circuits "E" and "C" are not galvanically separated from each other.

Connection of sensor

Type of sensor	Cable	Extension
Chlorine / chlorine dioxide sensors OCS140 / 141 / 240 / 241	3 m (9.8 ft) CMK, fixed cable	VBC junction box + OMK
Chlorine sensor 963	–	VBC junction box + MK
Temperature sensor for sensor 963	OPK1	
Total chlorine sensor OCS120	OPK9-N*A1B	VBC junction box + OYK71
pH or ORP sensor without temperature sensor	OPK1 for sensors with GSA plug-in head OPK9 for sensors with ESA plug-in head	VBC junction box + OYK71

Power supply

Depending on ordered version:
100/115/230 V AC +10/-15 %, 48 to 62 Hz
24 V AC/DC +20/-15 %

Power consumption

max. 7.5 VA

Mains protection

Fine-wire fuse, medium-slow blow 250 V/3.15 A

Performance characteristic

Cl₂/ClO₂ measurement

Measured value resolution OCS120/140/240 and 963:	0.01 mg/l
OCS141/241:	0.001 mg/l
Measurement deviation ¹ display (pH, T = const.) OCS140/141/240/241:	max. 0.5 % of measured value ±4 digits
OCS120 and 963:	max. 1 % of measured value ±4 digits
Repeatability:	max. 0.2 % of measuring range
Measurement deviation ¹ of signal output	max. 0.75 % of current output range

Temperature measurement

Measured value resolution:	0.1 °C
Measurement deviation ¹ of display:	±0.3 K
Measurement deviation ¹ signal output:	max. 1.25 % of current output range

pH and ORP measurement

pH measured value resolution:	pH 0.01
ORP measured value resolution:	1 mV
Measurement deviation ¹ of display pH:	pH 0.03
Measurement deviation ¹ of display ORP:	3 mV
Measurement deviation ¹ of pH signal output:	max. 1.25 % of current output range
Measurement deviation ¹ of ORP signal output:	max. 1.25 % of current output range

1) acc. to IEC 60746-1, at nominal operating conditions

Installation conditions

Installation instructions

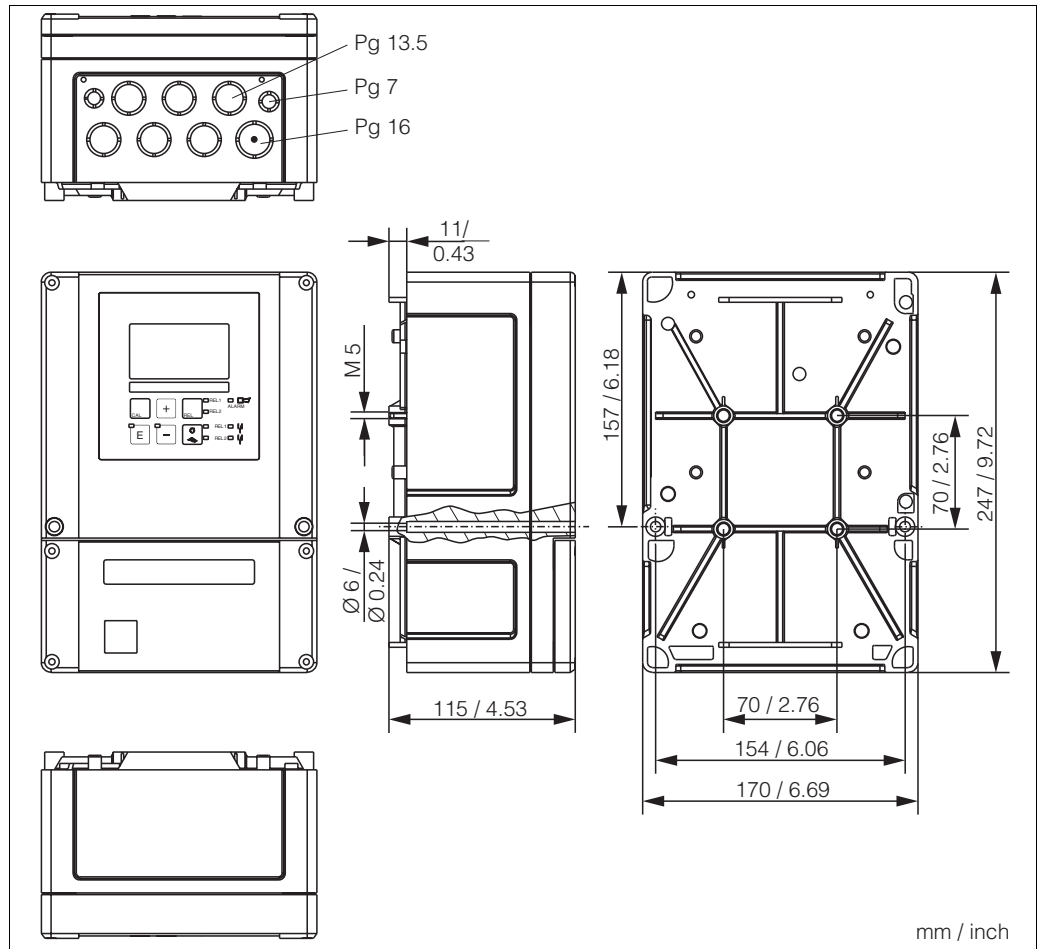

C07-CxM253xx-06-06-00-en-001.EPS

Field instrument

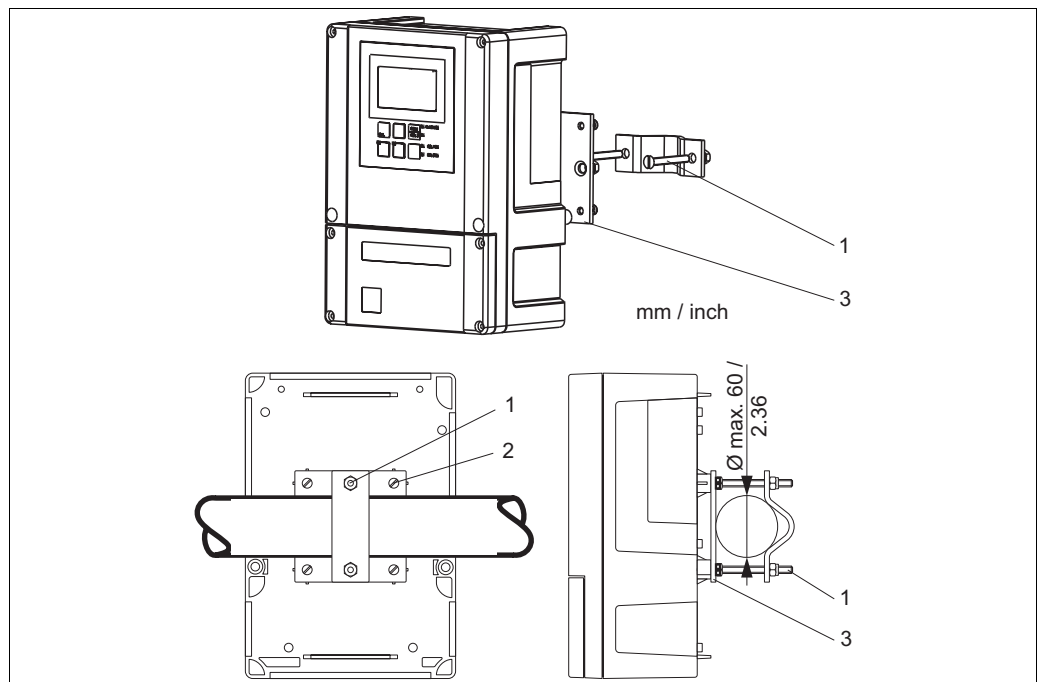

a0005737

Mounting on pipes

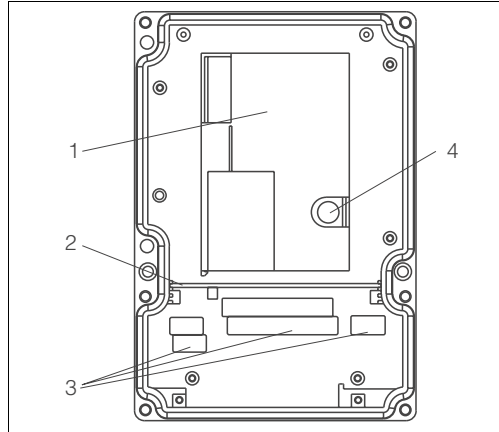

- 1 Removable electronics box
- 2 Partition plate
- 3 Terminal blocks
- 4 Fuse

C07-CxM253xx-11-06-00-xx-001.EPS

Inside of field instrument

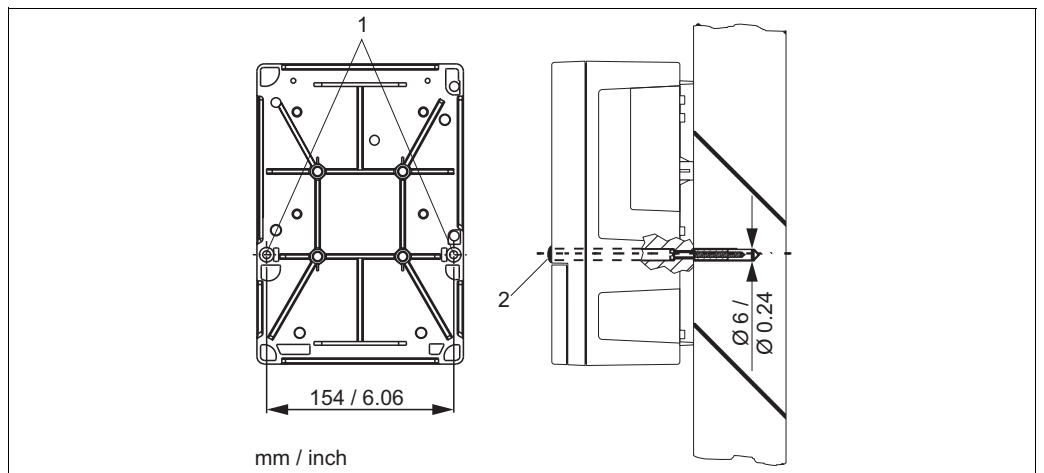

a0005736

Wall mounting of the field instrument

- 1 Mounting holes
- 2 Protecting cap

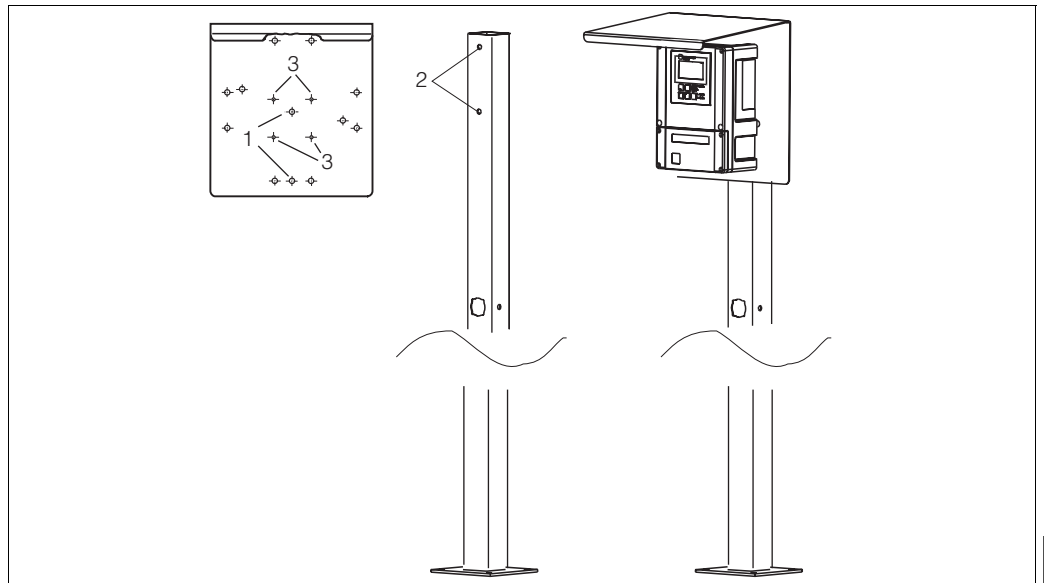

C07-CxM253xx-11-06-00-xx-004.EPS

Mounting of the field instrument with mounting post and weather protection cover

- 1 -3 Mounting holes

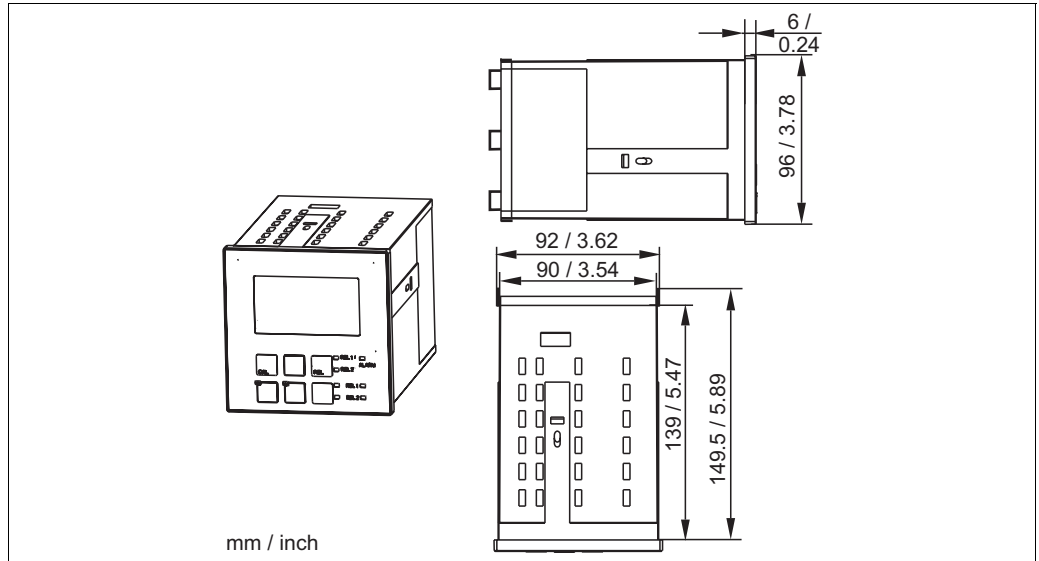

Dimensions panel-mounted instrument

a0005735

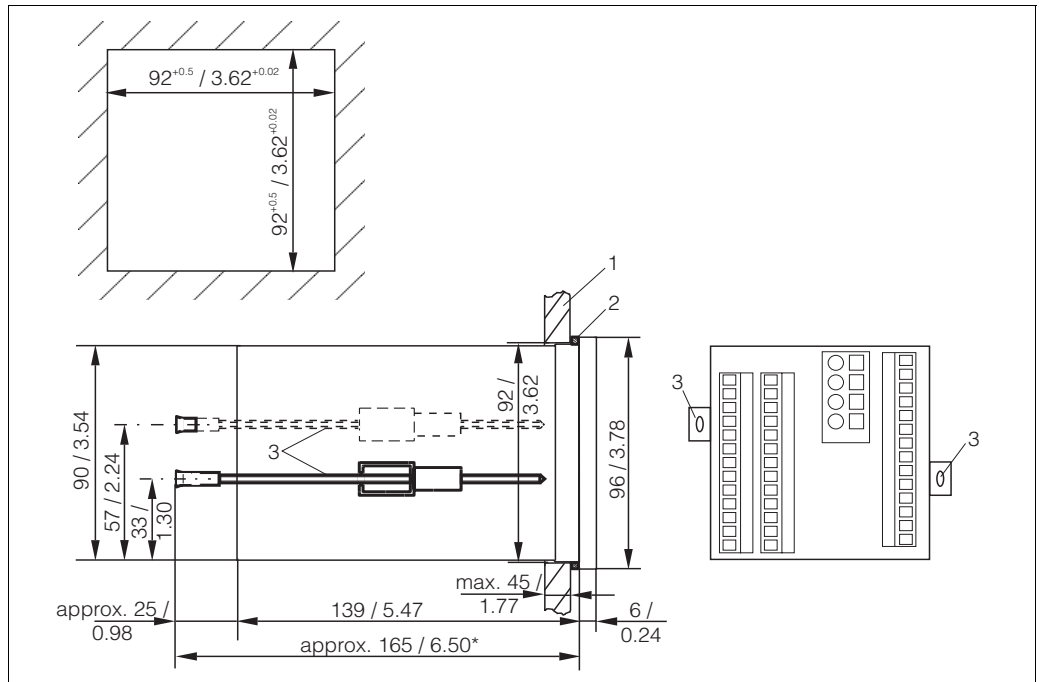

Installation of the panel-mounted instrument

C07-CxM223xx-11-06-00-en-001.EPS

- 1 Wall of control cabinet
- 2 Gasket
- 3 Tensioning screws
- * Required installation depth

Environment

Ambient temperature	-10 to +55 °C (+14 to +131 °F)	
Ambient temperature limit	-20 to +60 °C (-4 to +140 °F)	
Storage and transport temperature	-25 to +65 °C (-13 to +149 °F)	
Electromagnetic compatibility	Interference emission and interference immunity acc. to EN 61326: 1997 / A1: 1998	
Ingress protection	Panel-mounted instrument: Field instrument:	IP 54 (front), IP 30 (housing) IP 65
Relative humidity	10 to 95%, non-condensing	

Mechanical construction

Dimensions	Panel-mounted instrument: Field instrument:	96 x 96 x 145 mm (3.78 x 3.78 x 5.71 inches) Installation depth: approx. 165 mm (6.50") 247 x 170 x 115 mm (9.72 x 6.69 x 4.53 inches)
Weight	Panel-mounted instrument: Field instrument:	max. 0.7 kg (1.5 lb) max. 2.3 kg (5.1 lb)
Materials	Housing of panel-mounted instrument: Field housing: Front membrane:	Polycarbonate ABS PC Fr Polyester, UV-resistant
Terminals	Cross section	max. 2.5 mm ² (14 AWG)

Human interface

Display elements

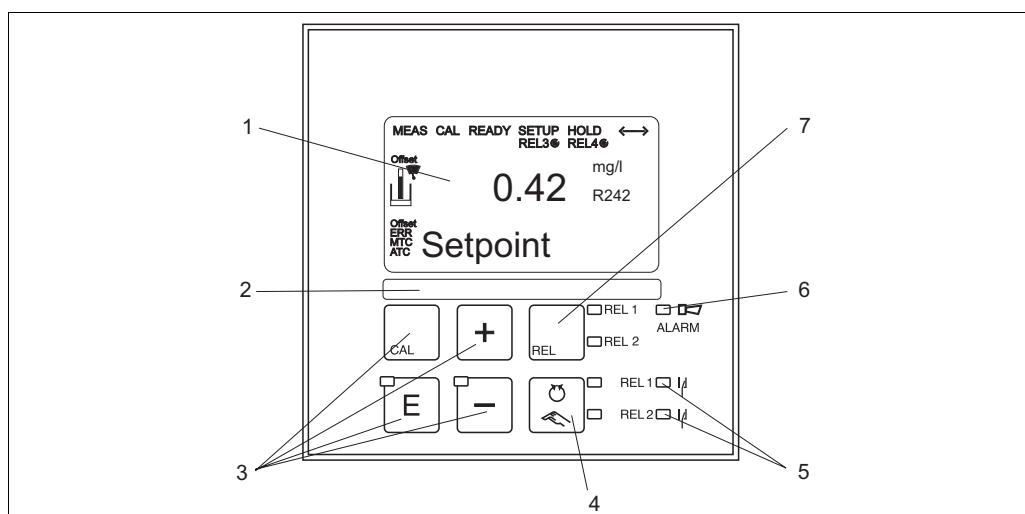

Operating elements

- 1 LC display for displaying the measured values and configuration data
- 2 Field for user labelling
- 3 4 main operating keys for calibration and device configuration
- 4 Changeover switch for automatic/manual mode of the relays
- 5 LEDs for limit contactor relay (switch status)
- 6 LED for alarm function
- 7 Display of the active contact and key for relay changeover in manual mode

Instrument control functions

All instrument control functions are arranged in a logical menu structure. Following access code entry, the individual parameters can be easily selected and modified as needed.

Certificates and approvals

CE symbol

Declaration of conformity

The product meets the legal requirements of the harmonized European standards. The manufacturer confirms compliance with the standards by affixing the CE symbol.

Ex approval for zone 2

Explosion protection for Zone 2

Version	Approval
OCM253-..6...	ATEX II 3G EEx nA[L] IIC T4
OCM253-..4... OCM223-..4... OCM223-..6...	ATEX II 3G [EEx nAL] IIC

Ordering information

Product structure

		Version	
	EK	Chlorine/chlorine dioxide/total chlorine measurement, basic version	
	ES	Chlorine/chlorine dioxide/total chlorine measurement, with additional functions (Plus package)	
	EP	Chlorine/chlorine dioxide/total chlorine measurement, with additional functions (Plus package) with additional pH or ORP measurement (switchable)	
		Power supply; approval	
	0	230 V AC	
	1	115 V AC	
	2	230 V AC; CSA Gen. Purp.	
	3	115 V AC; CSA Gen. Purp.	
	4	230 V AC; ATEX II 3G [EEx nAL] IIC	
	5	100 V AC	
	6	24 V AC/DC; ATEX II 3G [EEx nAL] IIC for OCM223, EEx nA[L] IIC T4 for OCM253	
	7	24 V AC/DC; CSA Gen. Purp.	
	8	24 V AC/DC	
		Output	
	0	1 x 20 mA, chlorine/chlorine dioxide/total chlorine	
	1	2 x 20 mA, chlorine/chlorine dioxide/total chlorine and temperature/main measured value/actuating variable	
	3	PROFIBUS PA	
	4	PROFIBUS DP	
	5	1 x 20 mA, chlorine/chlorine dioxide/total chlorine with HART®	
	6	2 x 20 mA, chlorine/chlorine dioxide/total chlorine with HART® and temp./main measured value/actuating variable	
		Additional contacts; analog input	
	05	Not selected	
	10	2 x relay (limit/controller/timer)	
	15	4 x relay (limit/controller/Chemoclean/3-point step controller for Cl ₂ /ClO ₂)	
	16	4 x relay (limit/controller/timer/3-point step controller for Cl ₂ /ClO ₂)	
	20	2 x relay (limit/controller/timer); current input	
	25	4 x relay with cleaning (limit/controller/Chemoclean/3-point step controller for Cl ₂ /ClO ₂); current input	
	26	4 x relay with timer (limit/controller/timer/3-point step controller for Cl ₂ /ClO ₂); current input	
OCM253-			
OCM223-			
			complete order code

Additional functions of the Plus package

Version ES

Compared to the basic EK version, this version is extended by the Plus package:

- Manual pH compensation for free chlorine, fields B2 and B3
- Current output table, fields O33x
- Sensor and process monitoring, function group P
- Automatic start of cleaning function, field F8.

Version EP

This version includes the functions of the ES version and in addition:

- Optional pH or ORP measurement, field B1
- Automatic pH compensation for free chlorine
- Sensor and process monitoring even for pH or ORP, fields P12x
- Limit contact for pH or ORP, fields R22x
- pH value control, fields R25x.

Scope of delivery

The delivery of the field instrument includes:

- 1 transmitter OCM253
- 1 plug-in screw terminal
- 1 cable gland Pg 7
- 1 cable gland Pg 16 reduced
- 2 cable glands Pg 13.5
- 1 Operating Instructions BA214e00
- versions with HART communication:
 - 1 Operating Instructions Field Communication with HART, BA208e00
- versions with PROFIBUS communication:
 - 1 Operating Instructions Field Communication with PROFIBUS PA/DP, BA209e00

The delivery of the panel-mounted instrument includes:

- 1 transmitter OCM223
- 1 set of plug-in screw terminals
- 2 tensioning screws
- 1 Operating Instructions BA214e00
- versions with HART communication:
 - 1 Operating Instructions Field Communication with HART, BA208e00
- versions with PROFIBUS communication:
 - 1 Operating Instructions Field Communication with PROFIBUS PA/DP, BA209e00

Accessories

Sensors

- OCS120
Amperometric sensor for total chlorine
measuring range 0.1 to 10 mg/l
Ordering acc. to product structure, see Technical Information (TI388e00)
- OCS140
Membrane-covered amperometric sensor for free chlorine
measuring range 0.05 to 20 mg/l
Ordering acc. to product structure, see Technical Information (TI058e00)
- OCS141
Membrane-covered amperometric trace sensor for free chlorine
measuring range 0.01 to 5 mg/l
Ordering acc. to product structure, see Technical Information (TI058e00)
- OCS240
Membrane-covered amperometric sensor for chlorine dioxide
measuring range 0.05 to 20 mg/l
Ordering acc. to product structure, see Technical Information (TI114e00)
- OCS241
Membrane-covered amperometric trace sensor for chlorine dioxide
measuring range 0.01 to 5 mg/l
Ordering acc. to product structure, see Technical Information (TI114e00)

Assemblies

- Flow assembly OCA250
for chlorine, chlorine dioxide, pH and ORP;
Ordering acc. to product structure, see Technical Information (TI062e00)
- Immersion assembly OYA611
for sensor immersion in basins, open channels and tanks, PVC;
Ordering acc. to product structure (Technical Information TI166e00)

Connection accessories

- OYK71 measuring cable
 - non-terminated cable for the connection of sensors or the extension of sensor cables
 - Sold by the meter, order numbers:
 - non-Ex version, black: 50085333
 - Ex version, blue: 51506616
 - OMK special measuring cable
for cable extension between junction box and transmitter, non terminated, sold by the metre
Order no. 50005374
 - OPK1 special measuring cable
For pH/ORP electrodes with GSA plug-in head
Ordering acc. to product structure, see Technical Information (TI118e00)
 - Special measuring cable OPK9-N*A1B internal PM wire
For sensors with TOP68 plug-in head, for high-temperature and high-pressure applications, IP 68
Ordering acc. to product structure, see Technical Information (TI118e00)
 - Extension cable MK
Two-wire signal cable with additional screen and PVC insulation. Particularly for the transmission of output signals of transmitters or input signals of controllers and for temperature measurement.
Order no. 50000662
 - Junction box VBC
Metallic junction box for cable extension,
dimensions (W x D x H): 125 x 80 x 54 mm / 4.92 x 3.15 x 2.13 inches
Order no. 50005181
- Junction box VBM
 - For cable extension, with 10 terminals
 - IP 65 / NEMA 4X
 - Material: aluminum
 - Order numbers:
 - cable entry Pg 13.5: 50003987
 - cable entry NPT ½": 51500177

Mounting accessories

- Weather protection cover OYY101 for mounting of field housing, for outdoor installation
material: stainless steel 1.4031;
order no. OYY101-A

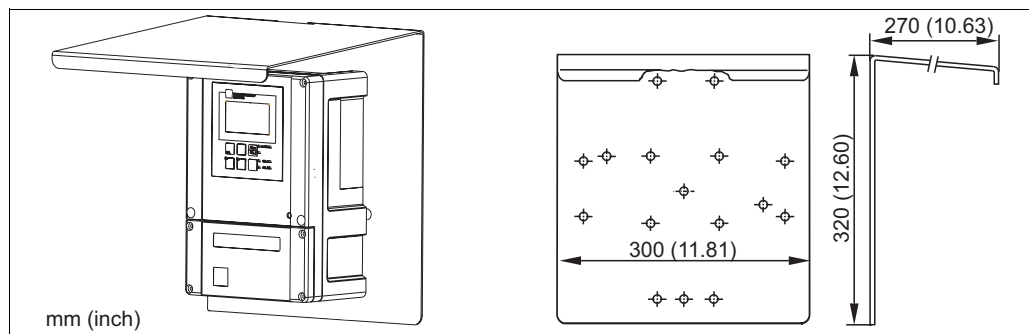

Weather protection cover for field instrument

- Kit for mounting of field housing on horizontal or vertical pipes (Ø max. 60 mm (2.36"))
order no. 50086842

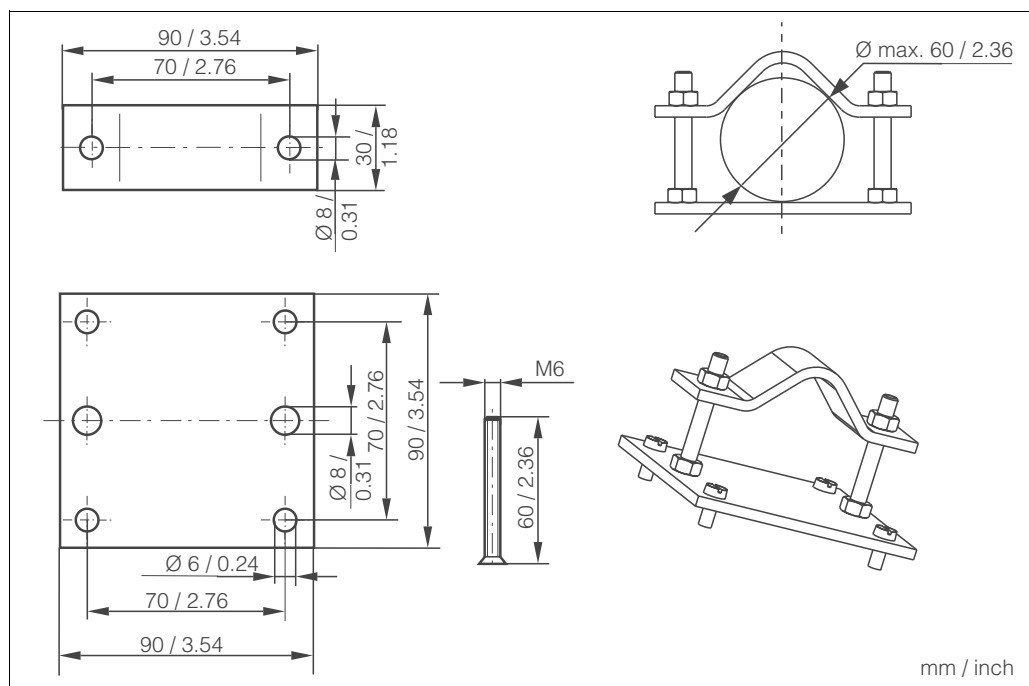

Pipe mounting kit

C07-0xM2x3xx-00-06-00-en-001.eps

- Universal upright post OYY102
 Square post for mounting of field housing, material: stainless steel 1.4301;
 order no. OYY102-A

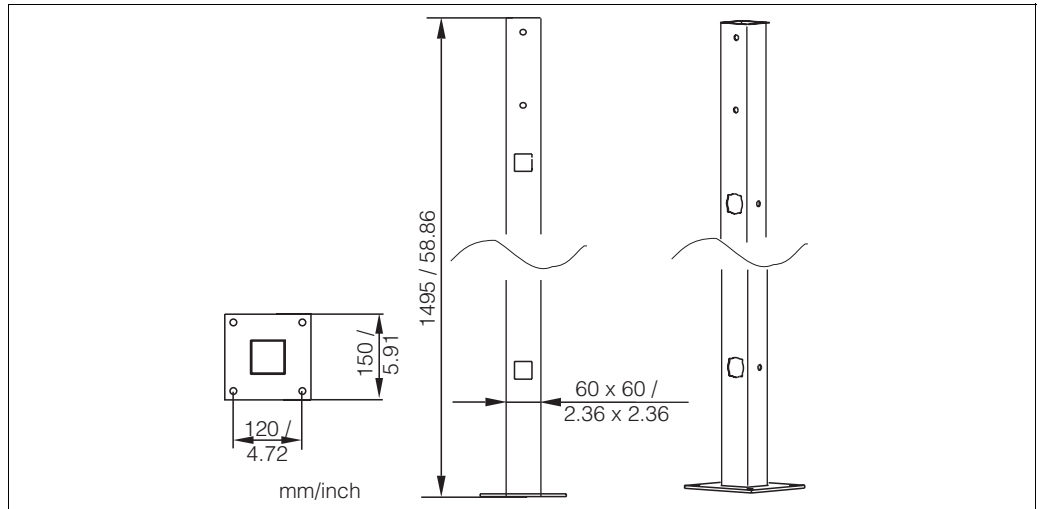

Square post OYY102

Measuring system

- Compact chlorine system OCE1
 Factory-assembled and wired panel for transmitter with flow assembly OCA250-A1; see also
 Technical Information TI014e00

Calibration tool

- Photometer OCM182; microprocessor-controlled photometer for chlorine, pH value, cyanuric acid;
 Chlorine measuring range: 0.05 to 6 mg/l
 pH measuring range: 6.5 to 8.4

Optoscope

- Optoscope
 Interface between transmitter and PC / laptop for service purposes.
 The Windows software "Scopeware" required for the PC or laptop is supplied with the
 Optoscope. The Optoscope is supplied in a sturdy plastic case with all the accessories required.
 Order no. 51500650

