

Technical Information

OPS12

ORP electrode with dirt-repellent PTFE diaphragm for standard applications in process and environmental technology



Application

- Long-term monitoring and limit monitoring of processes with stable process conditions
 - Paper industry
 - Plastics chemistry
 - Power plants (e.g. flue gas washers)
 - Incineration plants
 - Food industry
 - Breweries
- Water treatment
 - Drinking water
 - Cooling water
 - Well water

Your benefits

- Robust electrode requiring low maintenance thanks to large PTFE ring diaphragm
- Application under pressures of up to 6 bar (87 psi)
- Long service life due to double junction system of metal lead and thus long electrode poison diffusion path
- Various measuring elements for application in oxidising and reducing media

Function and system design

Measuring principle

Redox measurement

The redox potential is a unit of measurement for the state of equilibria between oxidising and reducing components of a medium. Redox potential is measured similarly to the pH value. A platinum or gold electrode is used instead of pH-sensitive membrane glass. Analog to the pH measurement, an integrated Ag/AgCl reference system is used as a reference electrode.

General properties

• Low maintenance

The dirt-repellent, sterilisable PTFE ring diaphragm of the OPS12 prevents blocking and assures long-time stability and accuracy.

• Long service life

The double junction system of the metal lead offers better protection from electrode poisons and guarantees a considerably longer service life.

• Durability

Depending on the ordered version, the electrode is pressure proof up to 6 bar / 87 psi and can be applied at temperatures of up to 135 °C / 275 °F.

Measuring system

A complete measuring system comprises:

- OPS12 ORP electrode
- transmitter, e.g. OPM223/253
- special measuring cable, e.g. OPK9
- immersion, flow or retractable assembly, e.g. OPA933

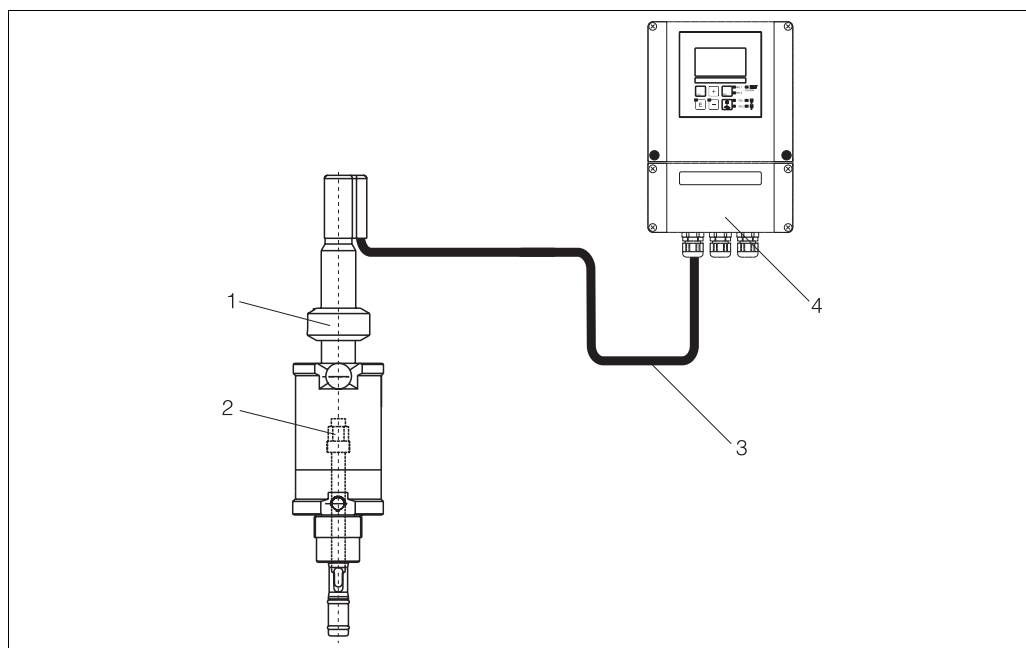

Measuring system for measurement of redox potential

- 1 Retractable OPA933 assembly
- 2 OPS12 ORP electrode
- 3 OPK9 special measuring cable (for electrodes with ESA plug-in head)
- 4 OPM253 transmitter

Input

Measured variables Redox potential

Measuring range -1500 ... 1500 mV



Caution!
Please note the process operating conditions.

Installation

Installation instructions

Do not install the electrode upside down. The inclination angle must be at least 15° from the horizontal. A smaller inclination angle is not permitted as such an inclination results in air cushion forming. This might impair the contact of reference and metal lead.



Caution!

- Make sure that the assembly's threaded connection for the electrode is clean and well running before installing the electrode.
- Hand tighten the electrode (3 Nm)! (Given value only applies to installation in OPA assemblies.)
- Make sure to follow the installation instructions in the operating instructions of the used assembly.

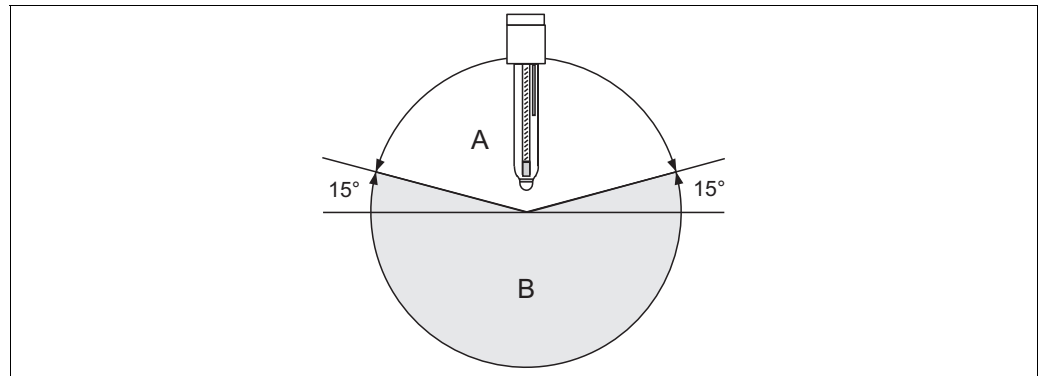

Electrode installation; inclination angle min. 15° from the horizontal

- A Permitted inclination angle
B Non-permitted inclination angle

Environment

Ambient temperature



Caution!
Danger of frost damage
Do not use the electrode at temperatures below -15 °C / 5 °F.

Storage temperature 0 ... 50 °C / 32 ... 122 °F

Ingress protection

IP 67: GSA plug-in head (with closed plug-in connection)
IP 68: ESA plug-in head (1 m / 3.28 ft water column, 50 °C / 122 °F, 168 h)

Process

Process temperature -15 ... 135 °C / 5 ... 275 °F

Process pressure 0 ... 6 bar / 0 ... 87 psi

Application

- Gold electrode
for oxidising media, e.g. cyanide oxidation, nitrite oxidation, ozone measurement, hydrogen superoxide measurement
- Platinum electrode
for reducing media, e.g. chromate reduction, chlorine dosing in swimming pools



Caution!

Danger of damage to the electrode

Never use the electrode in applications outside the given specifications!

Mechanical construction

Design, dimensions OPS12

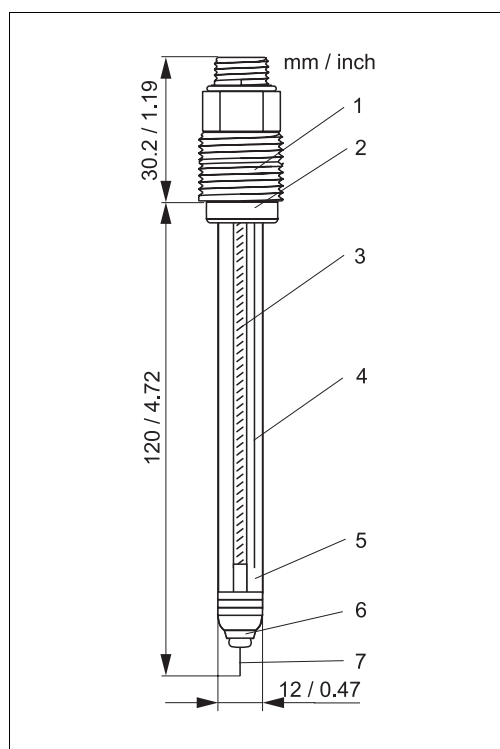

a0003689-en

OPS12 with GSA plug-in head

- 1 GSA plug-in head, PG 13.5
- 2 Viton O-ring with thrust collar
- 3 Inner metal lead
- 4 Ag/AgCl lead for the reference
- 5 "Advanced Gel" electrolyte
- 6 PTFE diaphragm
- 7 Gold pin or platinum surface

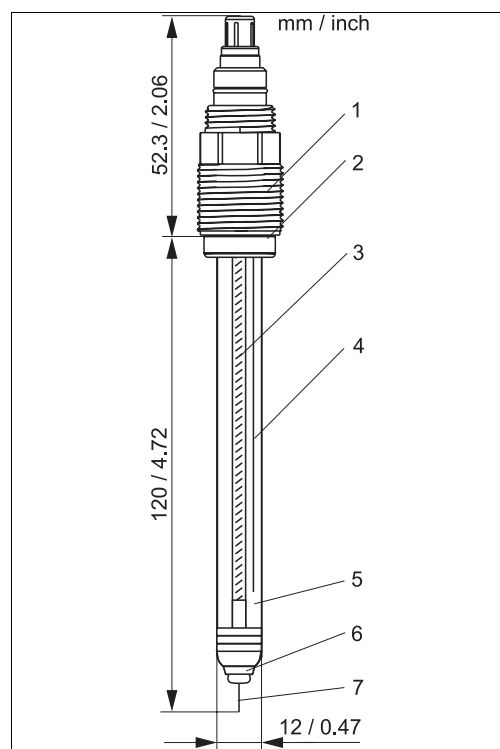

a0003688-en

OPS12 with ESA plug-in head

- 1 ESA plug-in head, Pg 13.5
- 2 Viton O-ring with thrust collar
- 3 Inner metal lead
- 4 Ag/AgCl lead for the reference
- 5 "Advanced Gel" electrolyte
- 6 PTFE diaphragm
- 7 Gold pin or platinum surface

Weight	0.1 kg / 0.2 lb.		
Material	Electrode shaft	glass, suitable for processes	
	Redox measuring element	platinum surface or gold pin	
	Diaphragm	ring-shaped Teflon® diaphragm, sterilisable	
Process connection	Pg 13.5		
Plug-in heads	ESA:	plug-in head Pg 13.5, TOP68	
	GSA:	plug-in head Pg 13.5	
Reference system	Ag/AgCl lead with Advanced Gel 3 M KCl, AgCl free		

Ordering information

Product structure OPS12

Electrode type				
	0	Standard type		
Measuring surface				
	NA	Gold pin		
	PA	Platinum surface		
Shaft length				
	2	120 mm / 4.72"		
Type of head				
	ESA	Plug-in head Pg 13.5, TOP68		
	GSA	Plug-in head Pg 13.5		
OPS12-				complete order code

Accessories



Note!

In the following sections, you find the accessories available at the time of issue of this documentation.

For information on accessories that are not listed here, please contact your responsible service.

Assemblies (Selection)	<ul style="list-style-type: none">• OPA450 Manually operated, retractable assembly for installation of 120 mm / 4.72" pH/redox electrodes in tanks and pipes• OPA933 Compact retractable stainless steel assembly for installation in tanks and pipes, manual or pneumatic operation• OPA935 Compact retractable plastic assembly for installation in tanks and pipes, manual or pneumatic operation• OPA111 Plastic immersion and installation assembly for open and closed tanks• OPA250 Flow assembly for pH/redox measurement
Buffer solutions	<p>Technical buffer solutions for ORP electrodes</p> <ul style="list-style-type: none">• +220 mV, pH 7.0, 100 ml (3.4 fl.oz.); order no. OPY3-0• +468 mV, pH 0.1, 100 ml (3.4 fl.oz.); order no. OPY3-1
Measuring cables	<ul style="list-style-type: none">• OPK9 special measuring cable For sensors with ESA plug-in head• OPK1 special measuring cable, with double screen and potential matching line For pH/redox electrodes with GSA plug-in head• OPK3 special measuring cable For pH/redox glass electrodes with GSA and NSA plug-in head



