

# ***CleanStar OPA 935 und 936*** **Retractable Assembly for Measuring pH/Redox**

## **Operating Instructions**

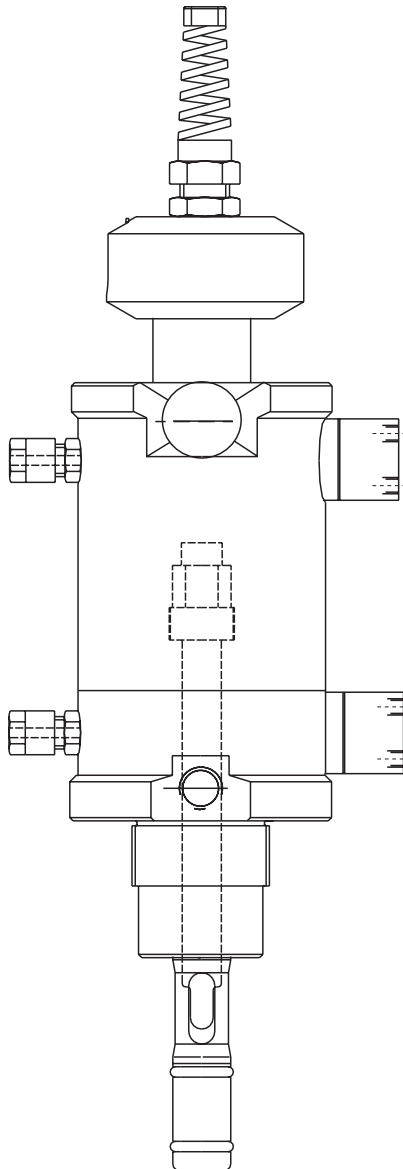



## Table of Contents

<b>1</b>	<b>Safety</b> .....	<b>2</b>	<b>5</b>	<b>Maintenance</b> .....	<b>20</b>
1.1	Safety symbols .....	2	5.1	Cleaning .....	20
1.2	Intended application .....	2	5.2	Calibration .....	21
1.3	Installation, start-up and operation .....	2	5.3	Repairs .....	23
1.4	Operational safety .....	3			
1.5	Return .....	3			
<b>2</b>	<b>Identification</b> .....	<b>4</b>	<b>6</b>	<b>Accessories</b> .....	<b>24</b>
2.1	Equipment name .....	4	6.1	Connection accessories .....	24
2.2	Scope of supply .....	7	6.2	Electrodes .....	24
2.3	Registered trademark .....	7	6.3	Spare parts .....	24
			6.4	Service-Kit .....	24
			6.5	Control of retractable assembly during cleaning / calibration .....	25
<b>3</b>	<b>Installation</b> .....	<b>8</b>	<b>7</b>	<b>Technical Data</b> .....	<b>26</b>
3.1	Measuring system .....	8			
3.2	Installation conditions .....	9			
3.3	Installation .....	12			
<b>4</b>	<b>Operation</b> .....	<b>18</b>			
4.1	Starting up the assembly .....	18			
4.2	Operating the OPA 935/936 in manual mode .....	18			
4.3	OPA 935/936 in pneumatic mode .....	19			
				<b>Index</b> .....	<b>28</b>

# 1 Safety

## 1.1 Safety symbols



Warning!

This symbol alerts you to hazards which could cause serious injuries as well as damage to the instrument if ignored.



Caution!

This symbol alerts you to possible faults which could arise from incorrect operation. They could cause damage to the instrument if ignored.



Note!

This symbol indicates important items of information.

## 1.2 Intended application

The hand-operated or pneumatically operated retractable assembly CleanStar OPA 935/936 is designed for installing pH/redox sensors in tanks and pipes.

Its mechanical design permits its use in pressurised systems (see Technical Data).

The responsibility for compliance with the following safety requirements lies with the operator:

- Explosion protection regulations
- Installation instructions
- Operating instructions for the assembly and its materials
- Local prevailing standards and regulations

## 1.3 Installation, start-up and operation



Warning!

- Installation, electrical connection, start-up, operation and maintenance of the measuring system must be carried out exclusively by trained specialists authorised by the system operator.
- Technical personnel must be familiar with the instructions in this manual and must adhere to them.
- When the assembly is operated in explosive atmospheres, it is imperative to comply with the regulations applicable.
- Before switching on the system check all the connections again for correctness.
- Do not operate damaged assemblies which could pose a danger, and mark them as defective.
- Measuring point faults may only be repaired by authorised and trained personnel.
- If faults cannot be repaired, the assembly must be taken out of service and secured against unintentional start-up.
- Repairs may only be carried out by the manufacturer or by an authorized service organisation.

## 1.4 Operational safety

The OPA 935/936 assembly has been designed for safety according to the state of the art and in compliance with the applicable regulations and EC directives (see Technical Data).

However, if it is used improperly or other than for its intended purpose, it may pose a hazard, e.g. through incorrect installation or the wrong operating conditions.



Warning!

- If the device is used for any application other than those described in this manual, it may lead to unsafe and improper functioning of the measuring system and is therefore not permitted.
- Make sure you strictly adhere to the warnings and notes in these Operating Instructions.

### Instructions for installation in pressurised systems



Warning!

- Do not exceed the maximum assembly operating pressure.
- Please pay attention to the pressure and temperature diagram.
- Depressurise the system before installing or removing the assembly.
- Inspect screw unions, valves and pipes for leaks or damage on a regular basis.

## 1.5 Return

If the assembly has to be repaired, please return it **cleaned** to the sales centre responsible. Please use the original packaging.

## 2 Identification

### 2.1 Equipment name

#### 2.1.1 Nameplate

The assembly variant is recognisable from the order code on the nameplate.

DIN ISO 9001	
Type / No.:	OPA 935 2625 /01
Ausführung / Code	3G4F2R
Material	PP / FPM
Steuerluft/control air	4-6 bar
Bemerkung	Pn. Endschalter

Abb. 2.1: Example for a nameplate of CleanStar OPA 935

### 2.1.2 Product structure

**Product structure  
CleanStar OPA 935**

					<b>Drive type and limit switches</b>	
					0	Manual (cannot be converted to pneumatic)
					1	Pneumatic without limit switches (suitable for retrofiting)
					3	Pneumatic with 2 pneumatic limit switches
					5	Pneumatic with 2 electric limit switches
					<b>Electrode type</b>	
					A	For gel electrodes with Pg 13.5, length 120 mm
					B	For KCl electrodes with Pg 13.5 hose connection head, length 225 mm
					<b>Assembly material (in contact with medium)</b>	
					1	PVDF with PVDF electrode holder
					2	PEEK
					3	PVDF with PEEK electrode holder
					4	PP
					<b>Seal material</b>	
					F	VITON <sup>®</sup> / FPM
					K	KALREZ <sup>®</sup>
					<b>Process connection</b>	
					1	NPT 1" external thread
					2	G 1¼ external thread
					6	Slotted nut Rd 78 DIN 11851-3 in stainless steel
					8	Flange DN 50 (for mounting on PFA flow vessel)
					<b>Optional equipment</b>	
					Y	Without rinse connection (retrofitting not possible)
					R	With rinse connection 2 x G ¼ internal thread
					N	With rinse connection 2 x NPT ¼" internal thread
OPA 935-						complete order code

**Product structure**  
**CleanStar OPA 936**

Drive type and limit switches				
	0			Manual (cannot be converted to pneumatic)
	1			Pneumatic without limit switches (suitable for retrofitting)
	3			Pneumatic with 2 pneumatic limit switches
	5			Pneumatic with 2 electric limit switches
Electrode type				
	A			For gel electrodes with Pg 13.5, length 225 mm
Assembly material (in contact with medium)				
	1			PVDF with PVDF electrode holder
	2			PEEK
	3			PVDF with PEEK electrode holder
	4			PP
Seal material				
	F			VITON <sup>®</sup> / FPM
	K			KALREZ <sup>®</sup>
Process connection				
	1			NPT 1" external thread
	2			G 1¼ external thread
	3			ANSI 2", flange
	6			Slotted nut Rd 78 DIN 11851-3 in stainless steel
	8			DN 50 flange
Optional equipment				
	Y			Without rinse connection (retrofitting not possible)
	R			With rinse connection 2 x G ¼ internal thread
	N			With rinse connection 2 x NPT ¼" internal thread
OPA 936-				complete order code



## 2.2 Scope of supply

Caution!

- Make sure the packaging is undamaged! If any damage is found, contact your postal service or forwarding agent. Keep any damaged packaging until matters have been clarified.
- Make sure the contents are undamaged! If any damage is found, contact your postal service or forwarding agent and inform the suppliers. Keep any damaged goods until matters have been clarified.
- Inspect the delivery for completeness and quantity according to the delivery papers, and the instrument type and version as shown on the nameplate.

The following items are included in the delivery:

- CleanStar OPA 935 resp. OPA 936 assembly
- Operating Instructions BA 223e00

In case of any queries, please contact your supplier or the sales centre responsible (see back page of these Operating Instructions).

## 2.3 Registered trademark

KALREZ®

Registered trademark of E.I. Du Pont de Nemours & Co., Wilmington, USA.  
Tradename for FFKM

VITON®

Registered trademark of E.I. Du Pont de Nemours & Co., Wilmington, USA.  
Tradename for FPM

## 3 Installation

The following procedure should be followed for a complete measuring system installation:

1. Mounting and connecting an electrode (see Chapter 3.3.1)
2. Water connection to rinse connections (see Chapter 3.3.2)
3. Installing the assembly (see Chapter 3.3).

### 3.1 Measuring system

A full measuring system comprises:

- Retractable assembly CleanStar OPA 935/936
- 1 pH combination electrode (120 or 225 mm)
- pH/redox measuring transmitter, e.g. OPM 223/253
- Measuring cable OPK 1, OPK 7 or OPK 9 (terminated)

#### Optional:

- Junction box VBA for measuring cable extension
- Measuring cable OYK 71 (unterminated) for measuring cable extension
- Cleaning device with injector OYR 10



Abb. 3.1: Complete measuring system for OPA 935 with OPM 223

### 3.2 Installation conditions

#### 3.2.1 Dimensions

Abb. 3.2: (left): Dimensions of CleanStar OPA 935 (for electrode length of 120 mm)

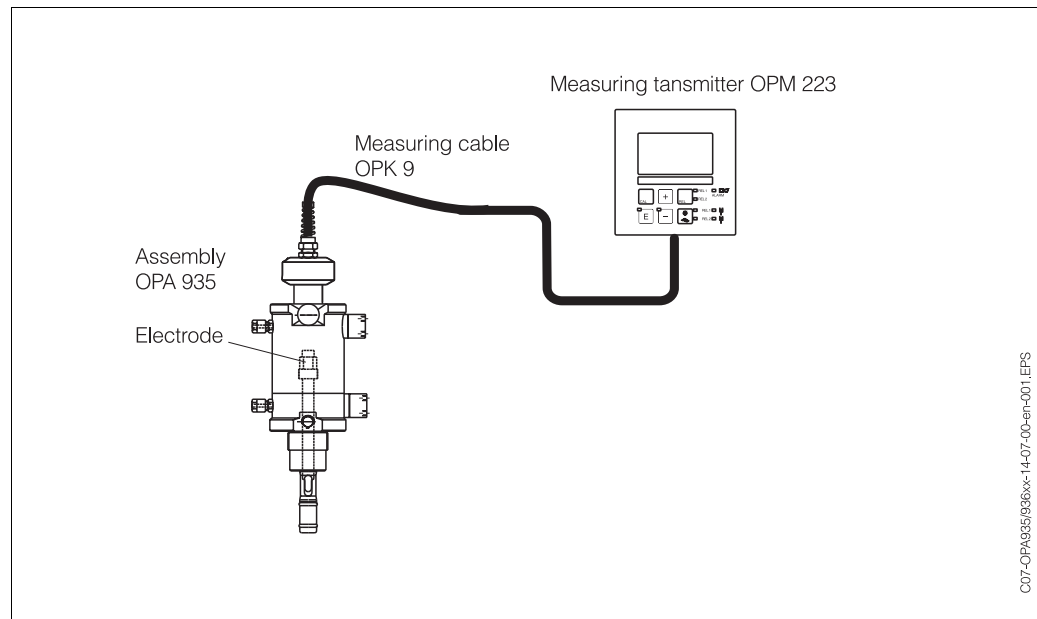
Abb. 3.3: (right): Dimensions of CleanStar OPA 936 (for electrode length of 225 mm)

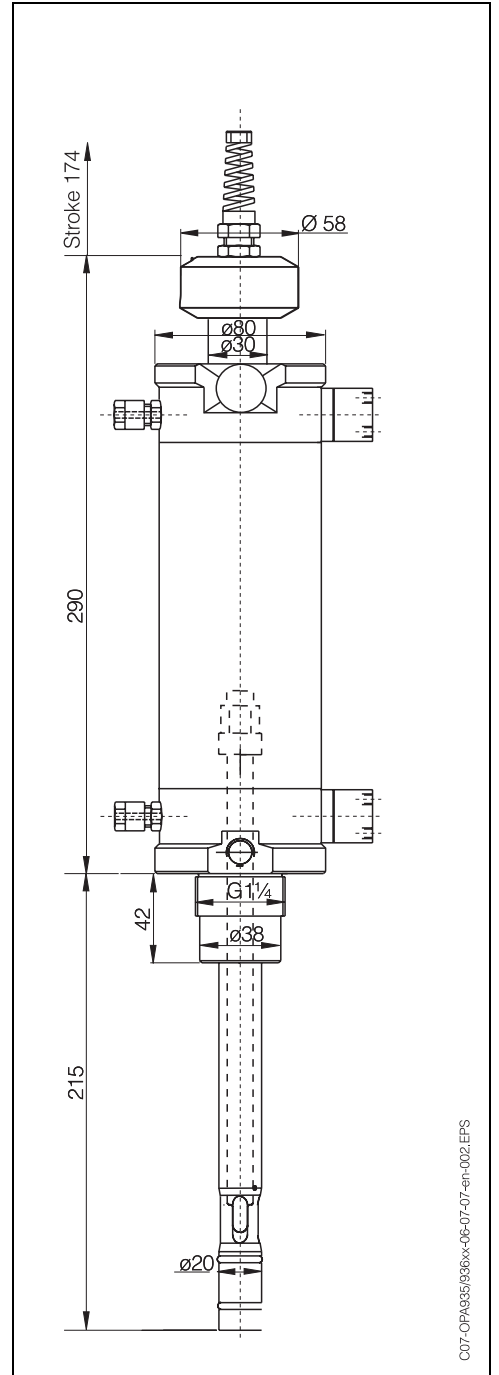
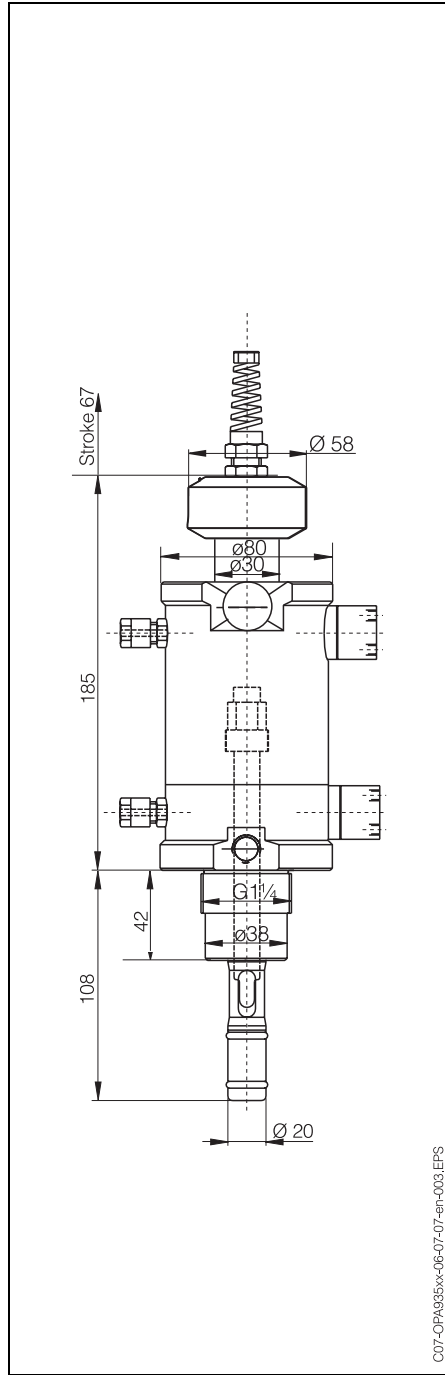



Abb. 3.4: Dimensions of CleanStar OPA 935 with 225 mm liquid KCl electrode OPS 41 (with hose connection for refilling with KCl)

### 3.2.2 Installation location/position

The CleanStar OPA 935/936 assembly is designed for installation on tanks or pipes. Suitable connections must be available.

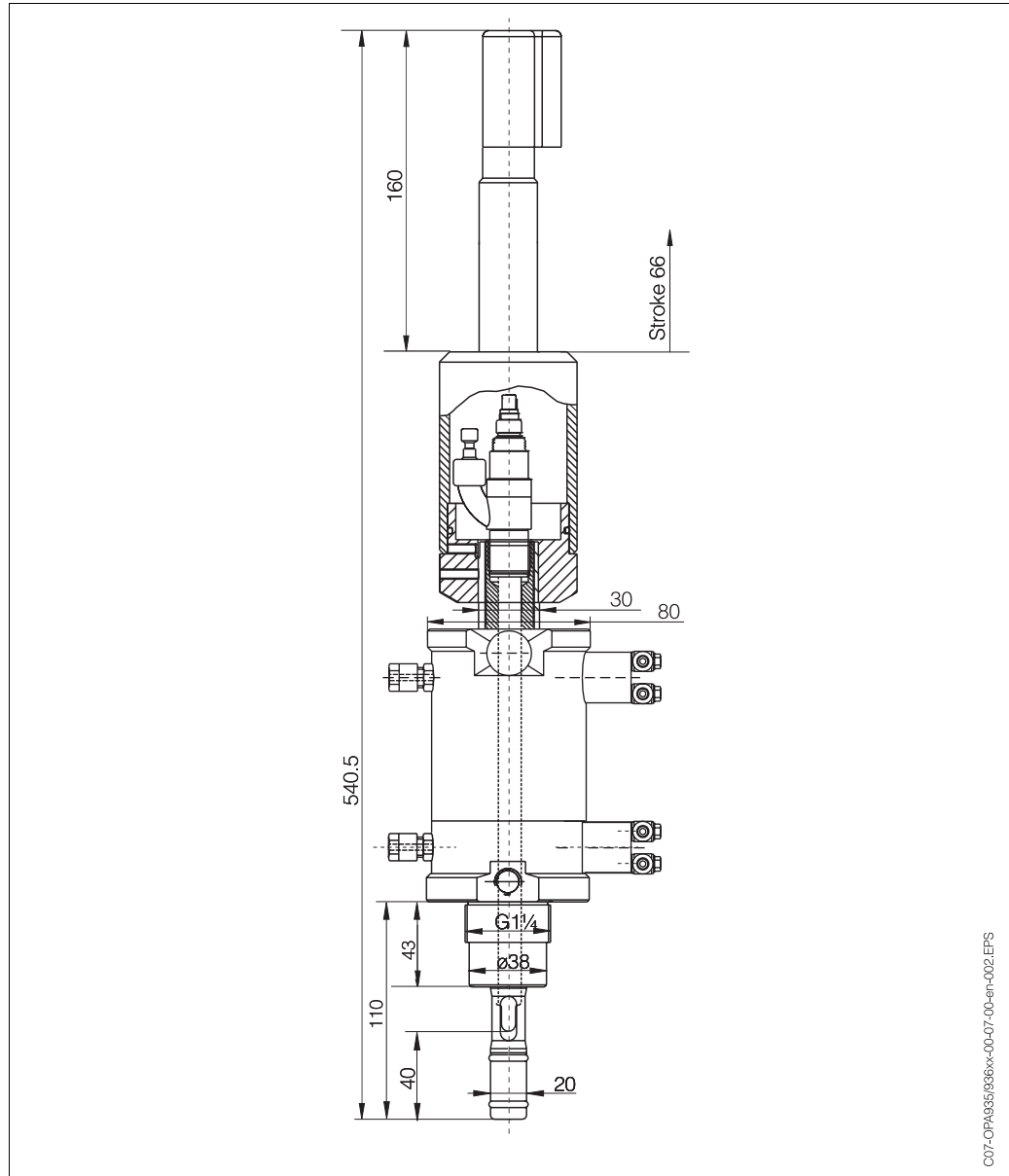

Note!

It is imperative to maintain an installation angle of min. 15°.



Abb. 3.5: Installation examples: The minimum installation angle is 15° to the horizontal.



Note!

- The assembly requires a minimum nominal width of DN 80 for installation in a pipe.
- For thinner pipes please use a flow vessel. These are available as accessories (DN 25, PVDF or DN 50, PP; for Order Numbers, see Accessories section).

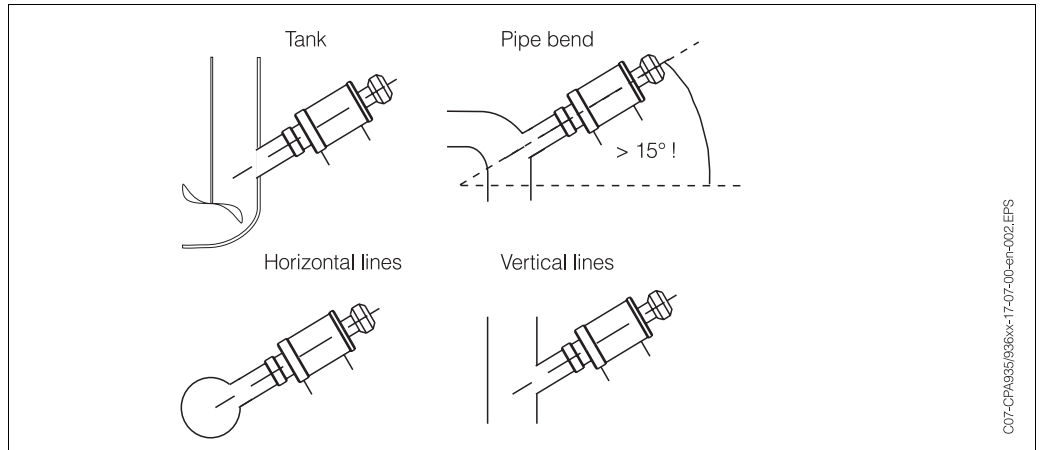

Abb. 3.6: Flow vessel for OPA 935/936  
 left: DN 25, PVDF  
 right: DN 50, PP



Caution!

Risk of frost damage!

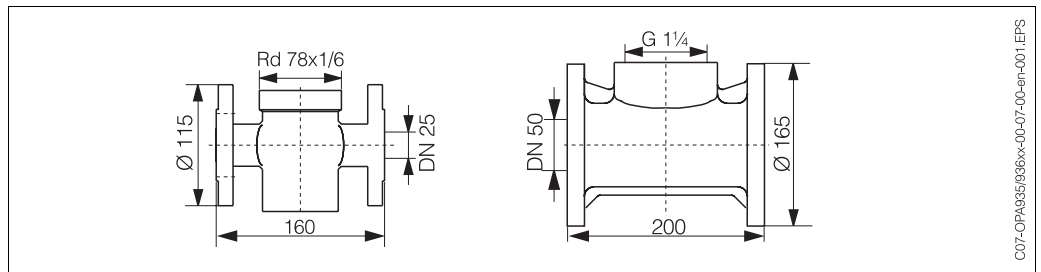
If there is a risk of temperatures dropping below 0°C, the assembly and any air or water tubes must be heated.

### 3.3 Installation



Abb. 3.7: Overview of mounting parts of CleanStar OPA 935/936

#### 3.3.1 Installing the electrode

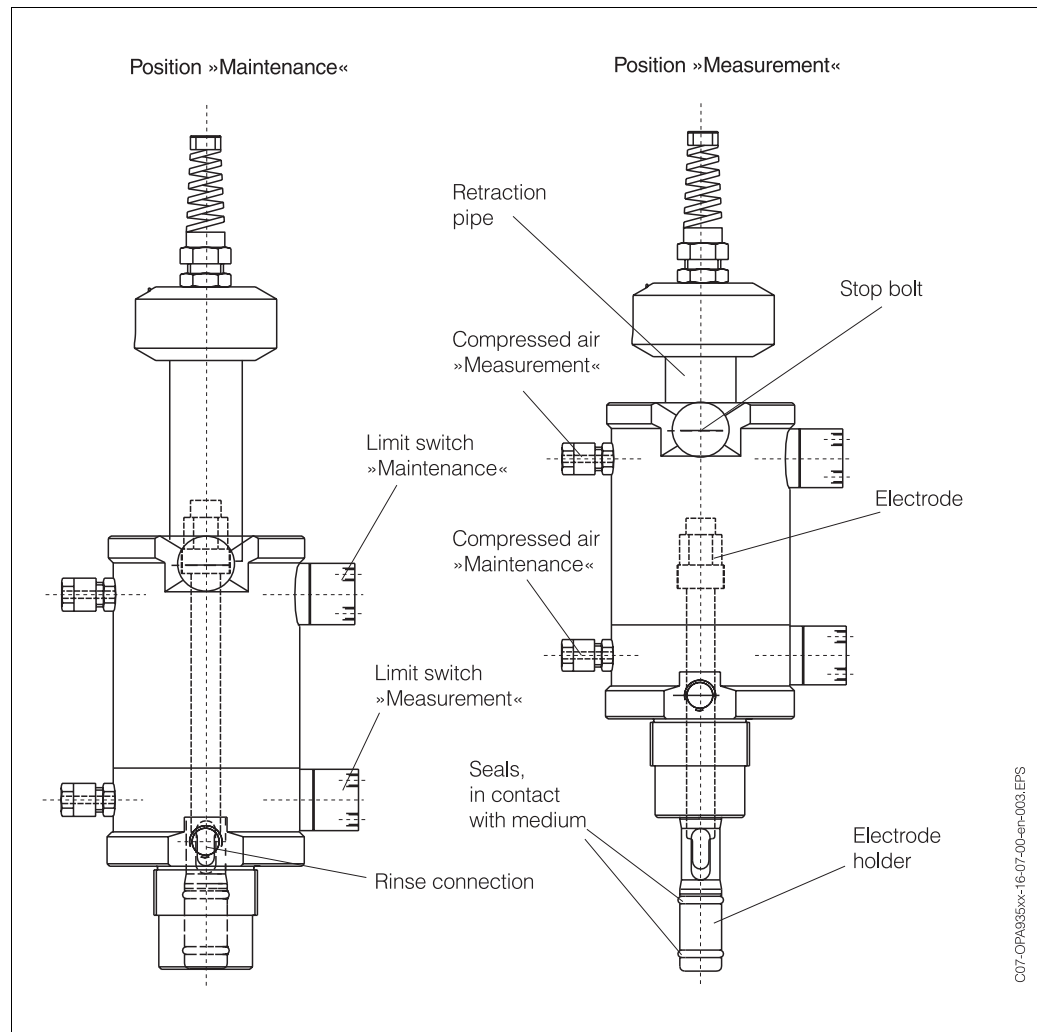

Note!

- Before installing a new electrode, make sure that the electrode shaft is fitted with O-ring B and thrust collar A and that the protection cap is removed.
- Moisten the electrode shaft before installing the electrode. Simply immerse in water.

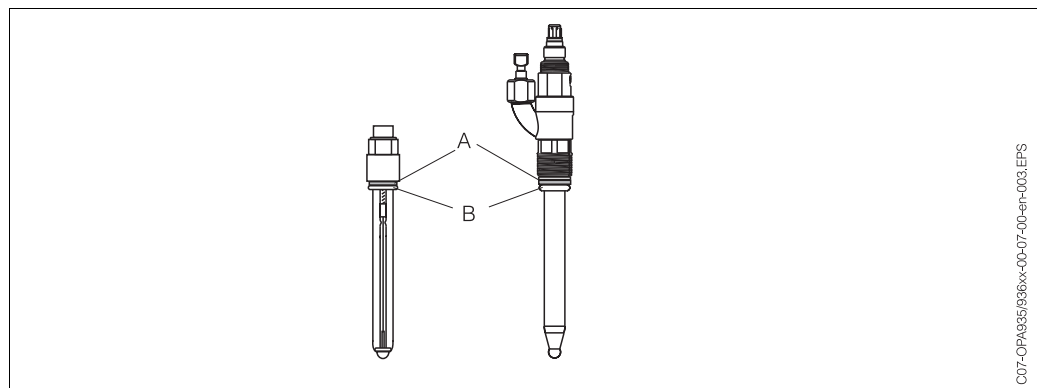

**Gel electrode,**

1. Pull lifting tube fully into assembly (in »Maintenance« position, see Fig. 3.7).
2. Turn stop bolt lock through 90° so that plastic grooves are located above the recesses.
3. Turn lifting tube clockwise until stop bolt lock engages.
4. Now remove lifting tube by turning anticlockwise.
5. Insert electrode hand-tight in electrode holder that is now visible and tighten by ¼ turn using socket spanner (17 AF).
6. Insert measuring cable from top through kink protection, handle and lifting tube.
7. Screw measuring cable on electrode plug-in head and tighten hand-tight.
8. Screw lifting tube hand-tight back on assembly.
9. Release stop bolt lock catch: Remove stop bolt lock and turn through 90°.
10. Insert measuring cable through the kink protection

Remove electrode in the reverse sequence of operations.



Abb. 3.8: top: Turn stop bolt lock through 90° so that plastic grooves are located above the recesses.  
bottom: When turning lifting tubes, stop bolt lock engages.

**KCl electrode**

1. Pull lifting tube fully into assembly (in »Maintenance« position, see Fig. 3.7)
2. Turn stop bolt lock through 90° so that plastic grooves are located above the recesses.
3. Turn lifting tube clockwise until stop bolt lock engages.
4. Remove splash protection cap
5. Now you can remove the lifting tube by turning anticlockwise.
6. Slacken and remove tension sleeve.
7. Remove electrode tube from lifting tube.
8. Insert electrode in electrode tube (①), screw it in and tighten with socket spanner (WAF17) by ¼ turn (②).
9. Insert electrode and electrode tube in lifting tube.
10. Insert tension sleeve from bottom in lifting tube (③) and screw to electrode tube (④).
11. Screw lifting tube and electrode hand-tight on assembly.
12. Insert measuring cable from top through protective tube and KCl hood.
13. Screw measuring cable on electrode plug-in head and tighten hand-tight.
14. Insert electrolyte supply tube through KCl hood and connect to electrode electrolyte connection.
15. Place measuring cable and electrolyte supply tube in splash protection cap and place this assembly on protection tube.
16. Release stop bolt lock: Remove stop bolt lock and turn through 90°.

Remove electrode in the reverse sequence of operations.

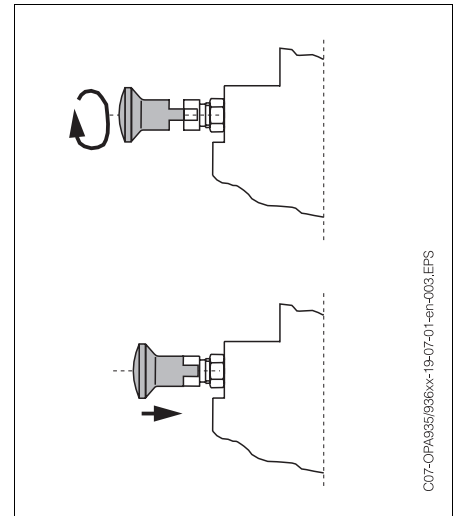

Abb. 3.9: Installing the liquid KCl electrode in the lifting tube



Abb. 3.10: Connections on OPS 41 electrode

### 3.3.2 Water connection (only on version with rinse connection)

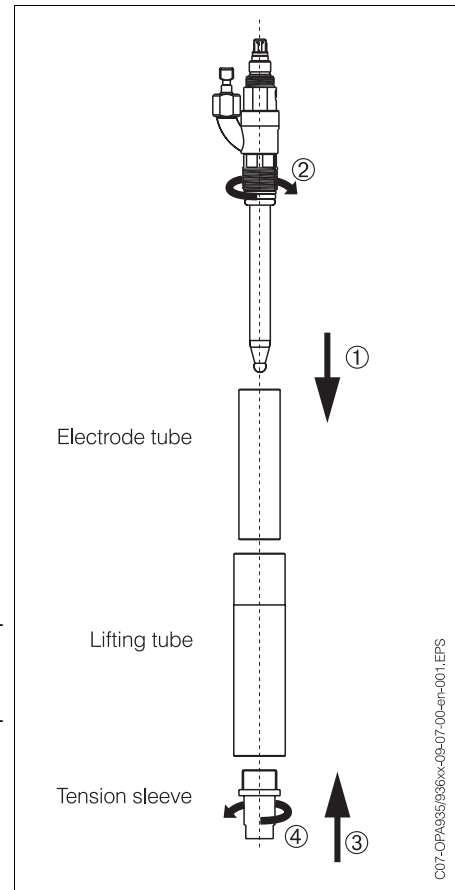
Connect the water supply to the rinse connections with internal thread provided (see Fig. 3.7). One connection is for the water inlet, the other is the water outlet. Make sure that the discharge is free and pressureless.

The CleanStar OPA 935/936 assembly is operated at a water pressure of 2 to 6 bar. A dirt trap and a non-return valve should be installed in the water supply line.

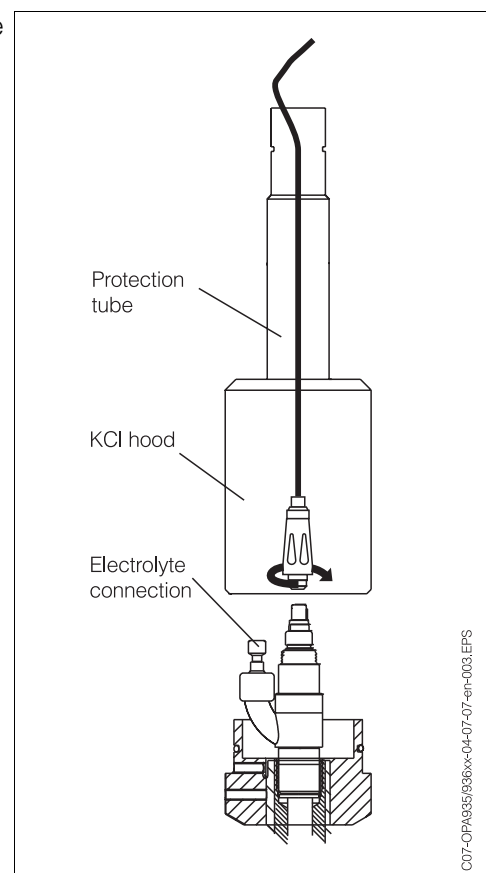

Note!

- If the water pressure can rise above 6 bar (including any transient pressure surges), install a pressure reducing valve upstream, otherwise the assembly may be damaged.
- The outlet should be located above the inlet as far as possible so that the electrode does not run dry in the rinse chamber.

Besides water, other or additional cleaning solutions may be used in the rinse chamber. However, pay attention to the material resistance of the assembly and comply with the maximum permitted temperatures (see Technical Data).

### 3.3.3 Compressed air connection to assembly control (only when equipped accordingly)



Abb. 3.11: Compressed air connections for CleanStar OPA 935/936

- Connect compressed air line for »Measurement« to upper 1/4" screw union.
- Connect compressed air line for »Maintenance« to lower 1/4" screw union.

The CleanStar OPA 935/936 assembly is operated at an air pressure of 4 to 6 bar. The air must be filtered (40 µm), and be water- and oil-free. There is no continuous air consumption.

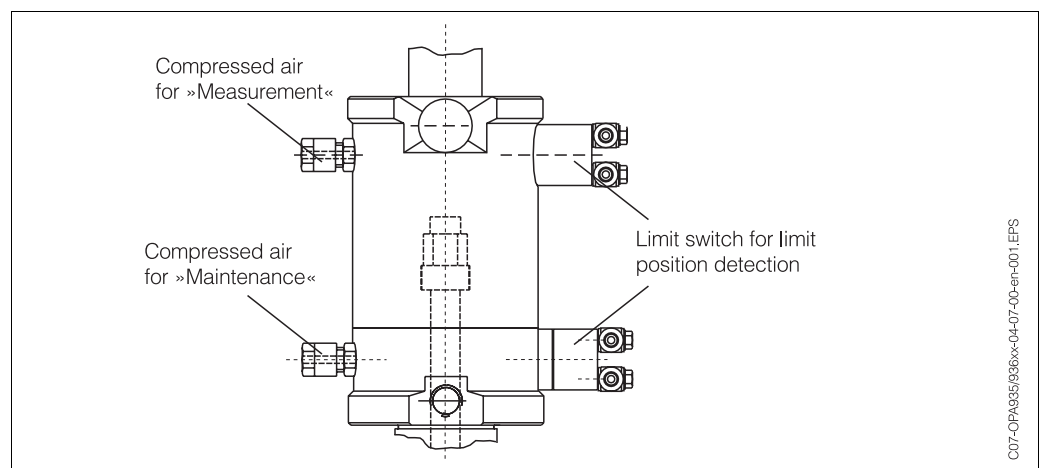

Note!

If the air pressure can rise above 6 bar (including any transient pressure surges), install a pressure reducing valve upstream, otherwise the assembly may be damaged.

### 3.3.4 Connecting the pneumatic limit switch (only when equipped accordingly)



Abb. 3.12: Pneumatic limit switch (1 = input, 2= output)

The lower limit switches are for the »Measurement« function and the upper switches for the »Maintenance« function.

The air lines must have a minimum nominal width of DN 4 mm.

Connect the pneumatic limit switches to the compressed air lines to the assembly control (see Chapter 3.3.3) as follows:

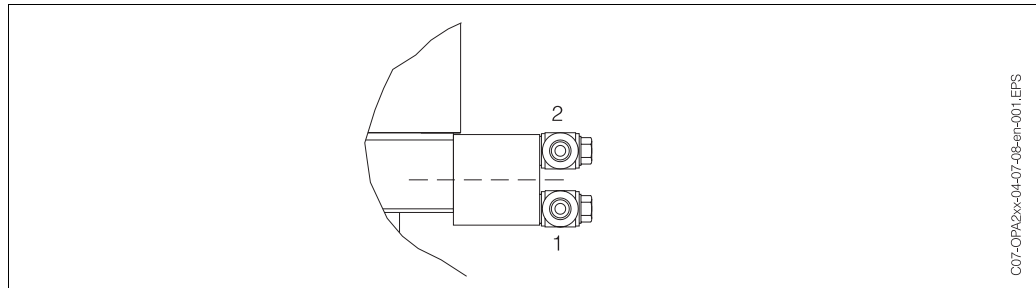

Abb. 3.13: Connection of the pneumatic lines to the CleanStar OPA 935/936 assembly  
1 = input, 2 = output

Connect the compressed air lines for the »Measurement« position feedback signal to the lower limit switch at the connections marked 1 (= inlet) and 2 (= outlet). When the »Measurement« position is reached, the air applied to inlet 1 is switched through and can be tapped at connection 2.

Connect the compressed air lines for the »Maintenance« position feedback signal to the upper limit switch at the connections marked 1 and 2. When the »Maintenance« position is reached, the air applied to inlet 1 is switched through and can be tapped at connection 2.

### 3.3.5 Installing the assembly

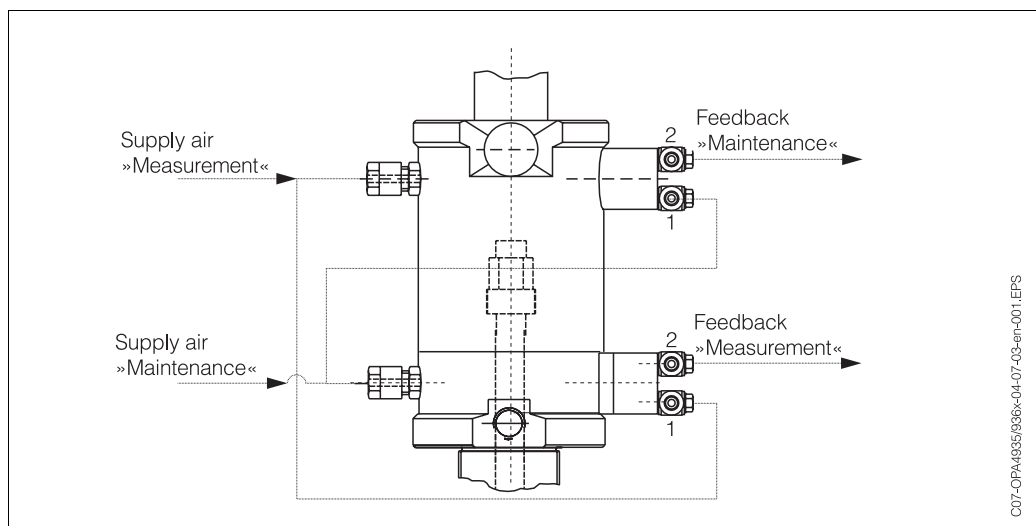
Set the assembly in maintenance position (see Fig. 3.7) and attach it to the selected connection on the tank or pipe.

Process connections are available for the CleanStar OPA 935/936 assembly:

G 1 1/4 external thread, flange DN 50, flange ANSI 2", NPT 1" external thread, grooved nut Rd 78



Abb. 3.14: Existing process connections for the CleanStar OPA 935/936 assembly  
The immersion depth is specified in each case



Note!

Note the following depending on the process connection fitted:

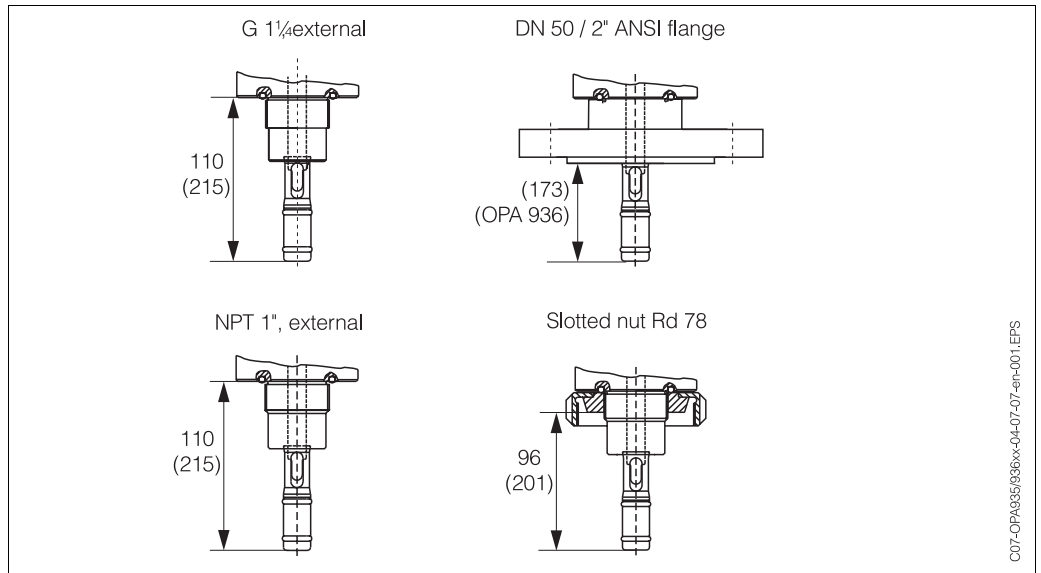
**All connections:**

- Check the correct seating of the O-rings on the assembly.



Abb. 3.15: O-ring seals of the CleanStar OPA 935/936 (in contact with medium)

**Flange connection:**

Check the seat of the flange seal between the flanges.

## 4 Operation

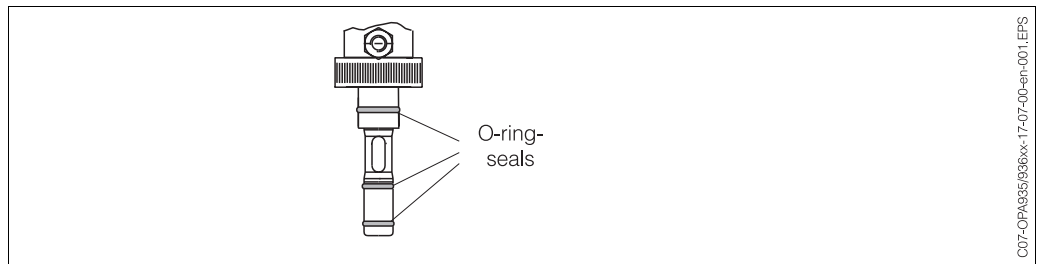
The assembly stop bolt lock arrests the lifting tube. Its operation is described in the two figures below:



Abb. 4.1: Release stop bolt lock:  
Remove stop bolt and turn through 90° so that the plastic grooves rest on the metal edge.



Abb. 4.2: Arrest stop bolt lock:  
left: Turn stop bolt lock through 90° so that the plastic grooves are located above the recesses  
right: When you turn the lifting tube clockwise, the stop bolt lock engages.

### 4.1 Starting up the assembly

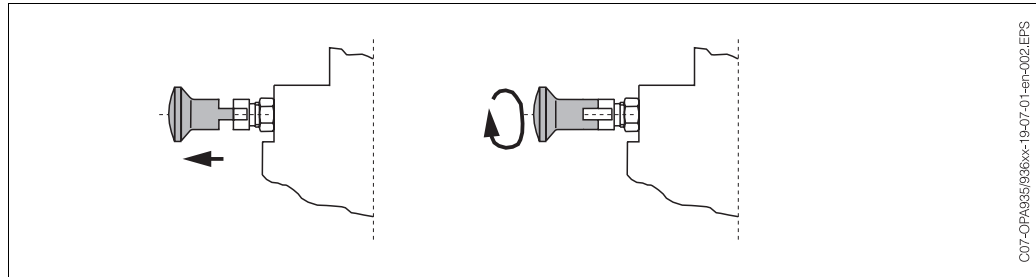

Note!

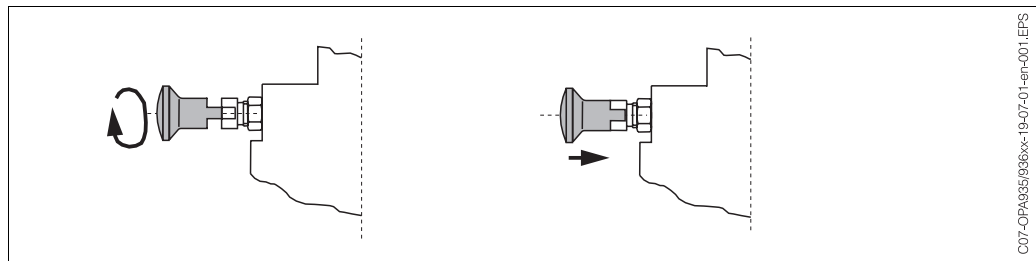
Before the first start-up, make sure of the following points:

- All seats are correctly seated (on the assembly and process connection)
- Electrode is correctly installed and connected
- Water supply line is correctly connected to the rinse connections (if fitted)
- Limit switches (depending on equipment fitted) are correctly connected

Caution!

Before applying compressed air to the pneumatic assembly, make sure the connection is correctly fitted!

### 4.2 Operating the OPA 935/936 in manual mode

#### »Measurement« process

- Release stop bolt lock catch.
- Introduce electrode and lifting tube completely in process.
- In this position, arrest electrode holder with stop bolt lock to prevent lifting tube from retracting unintentionally.



Warning!

Risk of injury! If the lifting tube is not arrested in the measurement position, the process pressure may exit uncontrolled and endanger the operator.

**»Maintenance« process**

- Release stop bolt lock catch.
- Pull lifting tube completely into assembly (in »Maintenance« position, see Fig. 3.7)
- Arrest electrode holder in this position with the stop bolt lock.
- Carry out maintenance work (see Chapter 5)

**4.3 OPA 935/936 in pneumatic mode**

Operating the pneumatic version depends on the control fitted. Refer to the control operating manual for instructions.

It is not possible to lock pneumatic assembly in »Measurement« position. The pneumatic system maintains the back-pressure to the process pressure.

**Caution!**

- During maintenance work (e.g. installing and removing electrode), lock the assembly in maintenance position using the stop bolt lock.
- During the automatic rinse process, do not arrest the lifting tube with the stop bolt lock, otherwise the assembly can no longer move automatically to the measurement position.
- If a maintenance switch is fitted on the measuring transmitter, set it to »Maintenance« or »Service«.

## 5 Maintenance



Warning!

Risk of injury! Before starting maintenance work on the assembly, make sure that the process line and the tank are depressurised, empty and rinsed. Move the assembly to the »Maintenance« position and arrest it using the stop bolt lock (see Fig. 4.2).

The measurement can be corrupted by electrode fouling or malfunction, e.g.:

- deposits on pH-sensitive part of glass electrode
  - Ⓜ causes poor response time and low sensitivity or shallow slope.
- fouling or blocking of diaphragm
  - Ⓜ causes poor response time and unstable measurement.

To ensure a reliable measurement, the electrodes must be cleaned at regular intervals. The frequency and intensity of the cleaning operation depend on the measuring medium.

### 5.1 Cleaning

Clean the electrode:

- before every calibration
- at regular intervals during operation as necessary.

Cleaning can take place manually by removing the electrode or via the rinse connection (if fitted).



Note!

- Do not use any abrasive cleaning agents for cleaning the electrodes. This can lead to irreparable damage to the measuring surfaces.
- After cleaning, rinse the rinse chamber with copious amounts of water (possibly distilled or de-ionised). Any residual cleaning agent can falsify the measurement drastically.
- After every cleaning operation, re-calibrate the measuring system.

#### Manual cleaning

All parts in contact with the medium, e.g. the electrode and the electrode holder, must be cleaned at regular intervals. Remove the electrode in the reverse sequence of operations 1 to 12 described in Chapter 3.3.1.

- Light dirt can be removed using suitable cleaning agents.
- Severe fouling must be removed with a soft brush and then a suitable cleaning agent.
- Remove persistent fouling by soaking in a liquid cleaner.

#### Selecting cleaning agents

The selection of cleaning agent depends on the type of fouling. The most frequent fouling and the associated cleaning agents are listed in the table below:

Type of contamination	Cleaning agent
Greases and oils	Substances containing tensides (alkaline) or water-soluble organic solvents (e.g. alcohol)
Calciferous deposits, metal hydroxide deposits, heavy biological deposits	3% HCl or with Chemoclean: HCl (10%) in injector thinned to approx. 3%
Sulphide deposits	Mixture of hydrochloric acid (3%) and thiocarbamide (commercially available)
Protein deposits	Mixture of hydrochloric acid (01 molar) and pepsin (commercially available)
Fibres, suspended substances	Water under pressure, poss. with surface-active agents
Light biological deposits	Water under pressure



Note!

- Do not use solvents containing halogen for cleaning. This could destroy the plastic components on the assembly.
- Only clean redox electrodes mechanically. Chemical cleaning applies a potential to the electrode that takes several hours to decay. This potential causes measuring errors.

## 5.2 Calibration

Careful and regular calibrations are indispensable to ensure reliable and precise measurement. Calibration cycles depend on the application and the required measurement accuracy.

In practice, calibration cycles must be determined on a case by case basis. At the start, we recommend frequent calibration, e.g. one a week, in order to familiarise yourself with the running characteristics.

When carrying out the calibration, always refer to the calibration instructions of the associated measuring transmitter (see Operating Instructions of the measuring transmitter).

### Calibration with electrode removed



Note!

- The calibration times depend on the process conditions and the measuring medium.
- Do not allow electrodes to stand in distilled water.
- Do not allow electrodes to stand dry.

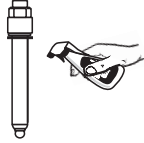
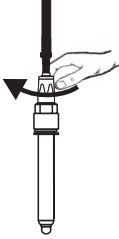
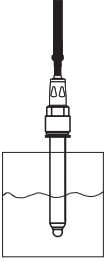
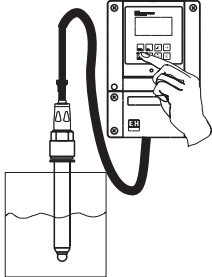
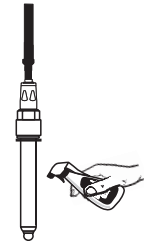
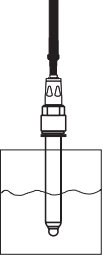
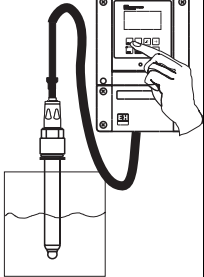
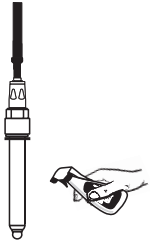
<p>① Remove electrode in reverse sequence of operations 1 to 12 (see section Installing the electrode).</p> <p><b>Warning:</b></p> <p> Only remove electrode with system depressurised.</p>	<p>② Clean and dry electrode. Check for mechanical damage.</p> 	<p>③ Screw electrode connector back on electrode head.</p> 	<p>④ Immerse electrode in buffer solution 1 (poss. with PM connection).</p> 
<p>⑤ Make settings on measuring system.</p> 	<p>⑥ Rinse electrode with distilled water.</p> 	<p>⑦ Immerse electrode in buffer solution 2 (poss. with PM connection).</p> 	<p>⑧ Make settings on measuring system.</p> 
<p>⑨ Rinse electrode with distilled water.</p> 	<p>⑩ Install electrode in assembly again acc. to steps 1 to 12 (see section Installing the electrode).</p>		

C07-OPA935/936xx-16-07-00-en-004.EPS

Abb. 5.1: Calibrating the electrode when removed

## 5.3 Repairs

The CleanStar OPA 935/936 retractable assembly largely requires very little maintenance. The following repair work is needed to ensure reliable operation:

- Replace damaged assembly parts.
- Keep O-rings and sealing surfaces on the assembly free of dirt.
- Grease dry O-rings.
- Inspect O-rings in contact with medium (see Fig. 3.15) regularly for damage and replace at reasonable intervals.
- Remove deposits clinging to the assembly for time to time.



Warning!

Any other intervention or modifications to the assembly are not permitted and will render all warranty claims null and void.

## 6 Accessories

We offer the following accessories specially designed for the OPA 935/936 retractable assemblies:

### 6.1 Connection accessories

- Weld-on connections
  - G 1¼ internal thread, PP; Order No.: A935Z-ES4
  - G 1¼ internal thread, PVDF; Order No: A935Z-ES1
  - Rd 78 external thread, PP; Order No: A935Z-ES4RD78
  - Rd 78 external thread, PVDF; Order No: A35Z-ES1RD78
- Flow vessel
  - DN 50, G 1¼ internal thread, PP; Order No: A935Z-DF504
  - DN 25, Rd 78 external thread, PVDF; Order No: A935Z-DF251
- Hose nozzle set for rinse fittings
  - G ¼, DN 12, PVDF (2 pcs); Order No: A935Z-ST12
- Retrofit set of limit switches
  - Set of pneumatic limit switches (2 pcs); Order No: A933Z-PS
  - Set of electric limit switches (2 pcs); Order No: A933Z-INI-NJ

### 6.2 Electrodes

- pH/redox combination electrodes, length 120 mm
  - Orbisint OPS 11/12
- pH/redox combination electrodes, length 225 mm
  - Orbisint OPS 11/12
  - Ceraliquid OPS 41/42 (with SSA or ESS head)
- Calibration solution OPY 2
- Measuring cable OPK 1, OPK 7 or OPK 9
  - e.g. OPK 1, 10 m, SSA head, up to 80°C; Order No. OPK1-100A
  - e.g. OPK 7, 10 m, SSA head, up to 80°C, Ex: Order No. OPK7-10Z
  - e.g. OPK 9, 10 m, SSA head, up to 130°C, Order No. OPK9-HBA1A

### 6.3 Spare parts

- Seat of seals, in contact with medium
  - VITON®; Order No: A935DISA-FPM
  - KALREZ®; Order No: A935DISA-KAL

### 6.4 Service-Kit

Retrofit Kit for OPA 935 from gel electrodes to liquid KCl electrodes (with OPS 41)

## **6.5 Control of retractable assembly during cleaning / calibration**

- OPM 223  
pH and redox measuring transmitter. Integrated electrode function monitoring, measured value monitoring, free configuration of alarm contact  
Technical Information TI 194e00 (Order No. 5152338)

## 7 Technical Data

General specifications	
Product name	CleanStar OPA 935/936
Ambient conditions	
Ambient temperature (nominal operating conditions)	> 0°C!
Process conditions	
Process temperature range	0 ... 90°C (dependent on selected material and process pressure)
Process pressure range	0 ... 4 bar in manual mode 0 ... 6 bar in pneumatic mode
Physical data	
Electrode* immersion depth	up to 110 mm OPA 935 up to 215 mm OPA 936
Required freedom of installation	approx. 0.5 m
Electrode lengths	120 mm, 225 mm
Weight of assembly	approx. 1.5 kg OPA 935 (short version) approx. 3 kg OPA 936 (long version)
Materials	
Materials in contact with medium	Electrode holder PP, PEEK, PVDF Seals: VITON®, KALREZ®
Materials in contact with medium	Housings PA
Process connections	
G 1¼ external thread, flange DN 50, flange ANSI 2", NPT 1" external thread, grooved nut Rd 78	
Network connections	
Rinse connections	2 x G ¼ (ID) 2 x NPT ¼" (ID) Rinse water pressure 2 ... 6 bar
Compressed air connections	Pressure 4 ... 6 bar air filtered (40 µm), water- and oil-free air tubes with minimum DN 4 mm
Limit switches	pneumatic 3/2-way valve

\* At an immersion depth of 215 mm no KCl electrodes (OPS 41) can be installed.



Abb. 7.1: Pressure-temperature chart for the CleanStar assembly OPA 935/936

Subject to modifications.

## Index

### A

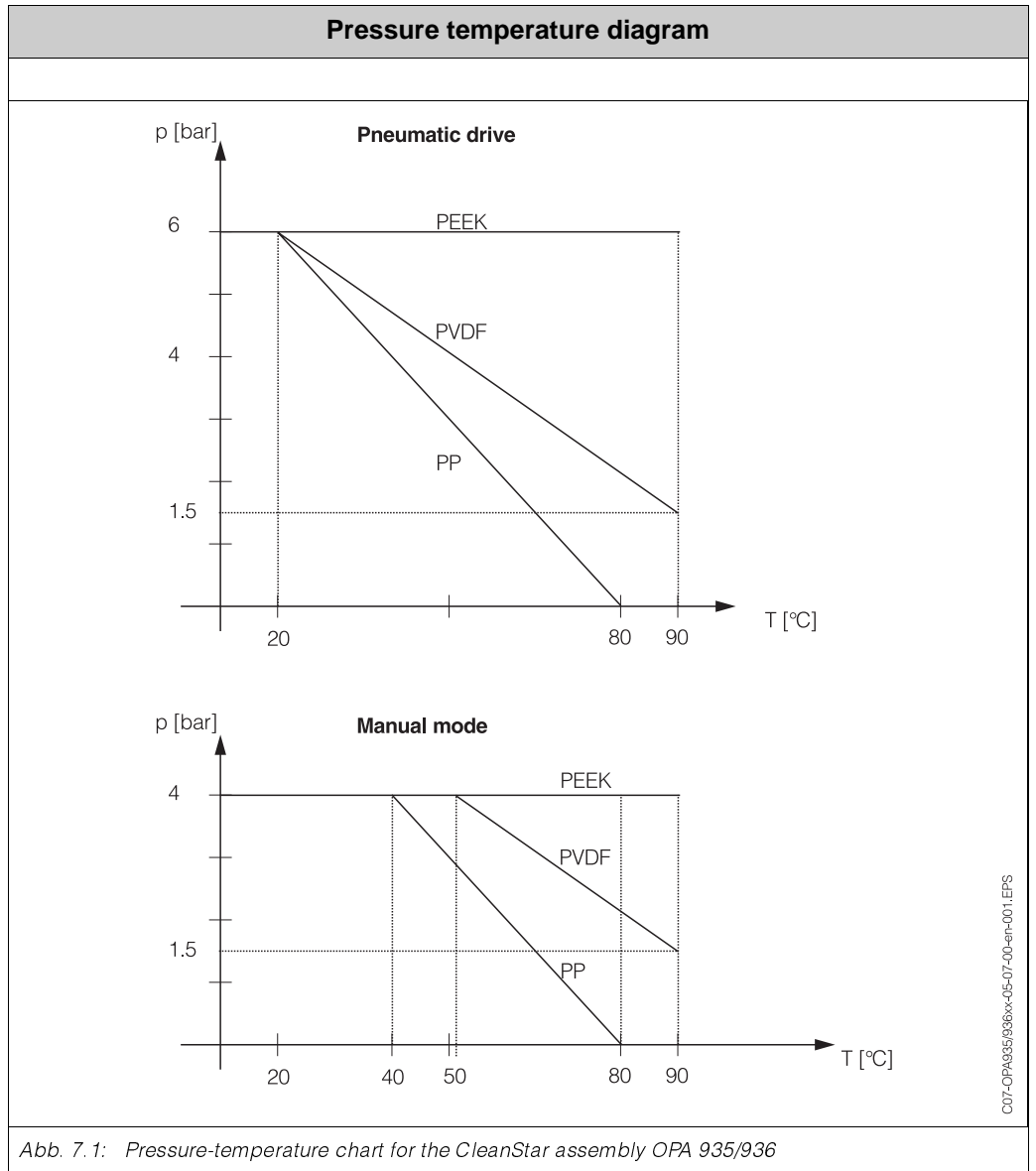
Accessories . . . . .	24
Air pressure . . . . .	15
Automatic cleaning . . . . .	25

### C

Calibration . . . . .	21
Cleaning . . . . .	20
Cleaning agents . . . . .	21
Cleaning via the rinse connection . . . . .	20
Complete installation . . . . .	8
Compressed air connection . . . . .	15
Connection accessories . . . . .	24

### D

Deposits . . . . .	21
Dimensions . . . . .	9

### E

Electrodes . . . . .	24
----------------------	----

### F

Flow vessel . . . . .	11
Fouling . . . . .	21
Frost . . . . .	11

### G

Gel electrode . . . . .	13
-------------------------	----

### I

Identification . . . . .	4
Installation . . . . .	2, 8, 12
Installation angle . . . . .	11
Installation position . . . . .	11
Installing the assembly . . . . .	17
Installing the electrode . . . . .	12
Intended application . . . . .	2

### K

KCl electrode . . . . .	10, 14
-------------------------	--------

### L

Limit switch . . . . .	12
Limit switch, pneumatic . . . . .	16

### M

Maintenance . . . . .	20–24
Maintenance, manual mode . . . . .	19
Manual cleaning . . . . .	20

Manual mode . . . . .	18
Measurement, manual mode . . . . .	18
Measuring system . . . . .	8
Monitoring and safety devices . . . . .	3

### N

Nameplate . . . . .	4
---------------------	---

### O

Operating pressure . . . . .	3
Operation . . . . .	2, 18
Operational safety . . . . .	3
O-rings . . . . .	17
Overview of mounting parts . . . . .	12

### P

Pipe diameter, minimum . . . . .	11
Pneumatic mode . . . . .	19
Pressure-temperature chart . . . . .	27
Process connections . . . . .	17
Product structure . . . . .	5

### Q

Queries . . . . .	7
-------------------	---

### R

Registered trademark . . . . .	7
Repairs . . . . .	23
Return . . . . .	3
Rinse connections . . . . .	15

### S

Safety . . . . .	2
Safety instructions . . . . .	2–3
Scope of supply . . . . .	7
Seat of seals . . . . .	24
Service-Kit . . . . .	24
Spare parts . . . . .	24
Start-up . . . . .	2, 18
Stop bolt lock . . . . .	18

### T

Technical Data . . . . .	26
--------------------------	----

### W

Water connection . . . . .	15
Water pressure . . . . .	15

# Gefahrgutblatt für Reparaturen Safety regulation form for repairs Bulletin de marchandises dangereuses pour réparations

Lieber Kunde, bitte helfen Sie uns mit Ihren Informationen, damit wir Ihre Reparatur schnell, exakt und risikofrei durchführen können.  
Dear customer, please help us with your information to handle your repair fast, exact and free of any risks for the technicians.  
Cher client, aidez-nous avec vos informations, afin que nous puissions exécuter vos réparations rapidement, exactement et sans risques.

Firma / company / entreprise: \_\_\_\_\_

Abt. / dept. / service: \_\_\_\_\_

Anschrift / adress / adresse: \_\_\_\_\_

Name / name / nom: \_\_\_\_\_

\_\_\_\_\_

Tel. / phone: \_\_\_\_\_

\_\_\_\_\_

Fax: \_\_\_\_\_

Sensortyp / type of sensor / modèle de détecteur: \_\_\_\_\_

Auswertegerät / type of instrument / type d'appareil: \_\_\_\_\_

Seriennummer / serial no. / numéro de série: \_\_\_\_\_

Seriennummer / serial no. / numéro de série: \_\_\_\_\_

## Prozessdaten / process data / données des opérations

Medium: \_\_\_\_\_

## Gereinigt mit / cleaned with / nettoyé avec

Medium: \_\_\_\_\_

Chemische Formel:  
Chemical formula:  
Formule chimique: \_\_\_\_\_



## Aggregatzustand / state of aggregation / état d'agrégation

flüssig/liquid  fest/solid   
liquide  solide   
gasförmig/gaseous  pulverig/powdery   
gazéiforme  poudreux

## Einbauort / mounting place / lieu de montage

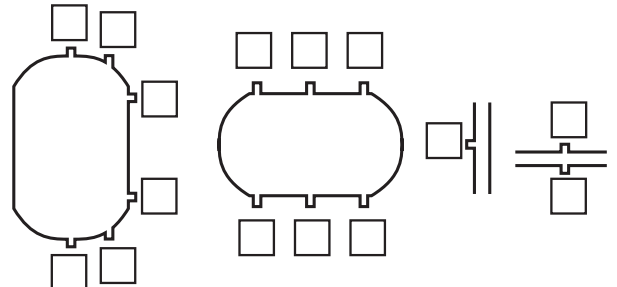

## Ex-Anlage / Ex-Zone / Ex-plan

Ja  Nein  Zone \_\_\_\_\_  
Yes  No  Class \_\_\_\_\_  
Oui  Non

## Sicherheitshinweise / safety regulations / normes de sécurité

 Umweltgefährlich Dangerous for the envir. Dangereux pour l'environ.	 Radioaktiv Radioactif	 Giftig Toxic Toxique	 Entzündlich Flammable Inflammable	 Brandfördernd Oxidizing Comburant	 Expl.gefährlich Explosive Explosif	 Schädlich / Reizend Harmful / Irritant Nocif / Irritant	 Ätzend Corrosive Corrosif	 Ungefährlich Safe to handle Sans danger
---	------------------------------	--------------------------------	---	---	--	---	-------------------------------------	---

- Hiermit bestätigen wir, dass die zurückgeschickten Geräte frei sind von jeglichen Gefahr- oder Giftstoffen (Säuren, Laugen, Lösungsmitteln, usw.). Radioaktiv kontaminierte Geräte müssen vor Einsendung entsprechend den Strahlenschutzvorschriften dekontaminiert werden. Falls spezielle Handhabungsvorschriften nötig sind, legen Sie diese bitte bei.
- We herewith confirm that the returned instruments are free of any dangerous or toxic materials (acids, caustics, solvents, etc.). Radioactive contaminated instruments must be decontaminated according to nuclear safety regulations prior to shipment. If special handling regulations are required, please attach.
- Par la présente, nous certifions que les instruments en retour sont exempts de tous risques de contamination ou de matières toxiques. Avant expédition les instruments contaminés par de la radio-activité doivent être décontaminés en référence aux prescriptions des règles de sécurité en vigueur contre les radiations nucléaires. Au cas où des règles de manipulations spécifiques sont nécessaires, veuillez les joindre s. v. p.

Datum / date: \_\_\_\_\_  
Firmenstempel / stamp / cachet: \_\_\_\_\_

Unterschrift: \_\_\_\_\_  
Signature: \_\_\_\_\_

**Distributed by:**



51506955