

# *OUM 223 / 253* Transmitter for Turbidity and Solids Content

## Operating Instructions

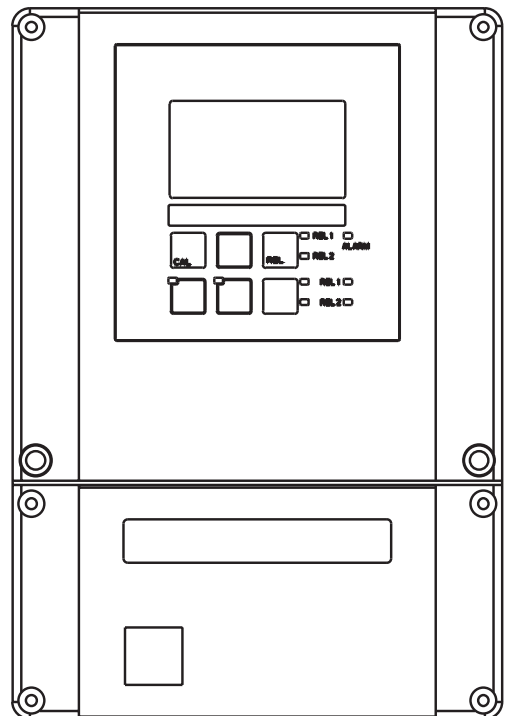

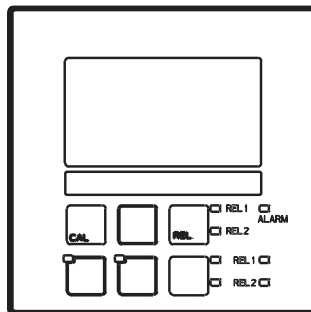

## Table of contents

<b>1</b>	<b>General information</b>	
1.1	Symbols used	2
1.2	Storage and transport	2
1.3	Unpacking	2
1.4	Dismantling, packaging and disposal	2
1.5	Product structure	3
<b>2</b>	<b>Safety instructions</b>	
2.1	Intended application	4
2.2	General safety notes	4
2.3	Installation, start-up, operation	4
2.4	Monitoring and safety features	5
2.5	Immunity to interference	5
2.6	Declaration of conformity	5
<b>3</b>	<b>Installation</b>	
3.1	Measuring system	6
3.2	Dimensions	7
3.3	Mounting	8
3.4	Electrical connection	12
3.5	Sensor installation and measuring cable connection	14
<b>4</b>	<b>Operation</b>	
4.1	Operator interface	16
4.2	Display	16
4.3	Function of the operating keys	17
4.4	Auto / manual mode of operation	18
4.5	Operating concept	19
<b>5</b>	<b>Instrument configuration</b>	
5.1	Start-up	24
5.2	System configuration	24
5.3	Current input	27
5.4	Current outputs	30
5.5	Monitoring functions	33
5.6	Relay contact configuration	37
5.7	Concentration measurement	48
5.8	Service 1	49
5.9	Service 2	51
5.10	Interfaces	52
5.11	Calibration	53
5.12	Offset	61
5.13	Slope	62
<b>6</b>	<b>Interfaces</b>	
<b>7</b>	<b>Maintenance and troubleshooting</b>	
7.1	Troubleshooting common problems	64
7.2	Troubleshooting using the error messages	67
<b>8</b>	<b>Diagnosis and corrective maintenance</b>	
8.1	Diagnosis	69
8.2	Corrective maintenance of OUM 223	71
8.3	Corrective maintenance of OUM 253	74
8.4	Spare parts orders	77
8.5	Service aids "Optoscope" with "Scopeware"	77
8.6	Corrective maintenance of measuring system	78
<b>9</b>	<b>Accessories</b>	<b>80</b>
<b>10</b>	<b>Technical data</b>	<b>82</b>
<b>11</b>	<b>Appendix</b>	<b>86</b>
<b>12</b>	<b>Index</b>	<b>90</b>

# 1 General information

## 1.1 Symbols used



### Warning:

This symbol alerts to hazards which could cause serious injuries as well as damage to the equipment if ignored.



### Caution:

This symbol alerts to possible faults which could arise from incorrect operation. They could cause damage to the equipment if ignored.



### Note:

This symbol indicates important items of information.



### Double insulation

Equipment protected by double insulation.



### Alarm relay



### Input



### Output

## 1.2 Storage and transport

The packaging material used to store or transport the transmitter must provide shock protection. Optimal protection is provided by the original packaging materials.

Conformance with the ambient conditions (see Technical data) must be assured.

## 1.3 Unpacking

Verify that the packaging and the contents are undamaged! Inform the post office or freight carrier of any damage. Damaged merchandise must be retained until the matter has been settled.

Keep the original packaging materials for future storage or shipping of the instrument.

If you have any questions, consult your supplier or your sales agency in your area.

Check that the delivery is complete and agrees with the shipping documents and your order (refer to nameplate for type and version).

The delivery includes:

- Transmitter OUM 223 (panel-mounted instrument) or OUM 253 (field device)
- Operating instructions BA 200e00
- Panel-mounted instrument:
  - 1 set of plug-in screw terminals
  - 2 clamping screws for panel mounting
- Field instrument:
  - 1 plug-in screw terminal
  - 1 x cable gland Pg 7
  - 1 x cable gland Pg 16, reduced
  - 2 x cable glands Pg 13.5
  - 1 x NPT adapter set (optional for CSA versions)

## 1.4 Dismantling, packaging and disposal

Package the assembly properly for reuse at a later point in time. Optimal protection is

provided by the original packaging materials. Observe local regulations for disposal.

### 1.5 Product structure

You can identify the instrument variant by the order code on the nameplate. Under “Codes”, you can find the release code for Software upgrade for ChemoClean (left of diagonal line) or Plus package (right of diagonal line).

<b>OUM 253 turbidity</b>			
order code	OUM 253-TS0115		
serial no.	276944	codes	- 3472 / 8732
meas. range	0 ... 9999 ppm		0 ... 200%
temperature	-10 ... 60°C		
output 1	0/4 ... 20 mA	output 2	0/4 ... 20 mA
mains	230 VAC		50/60 Hz 7.5 VA
prot. class	IP 65 ambient temp. -10 ... +55°C		
			131085-4D
253-TYP.CDR			

<b>OUM 223 turbidity</b>			
order code	OUM 223-TS0115		
serial no.	276945	codes	- 3472 / 8732
meas. range	0 ... 9999 ppm		0 ... 200%
temperature	-10 ... 60°C		
output 1	0/4 ... 20 mA	output 2	0/4 ... 20 mA
mains	230 VAC		50/60 Hz 7.5 VA
prot. class	IP 54 / IP 30 ambient temp. -10 ... +55°C		
			131085-4D
223-TYP.CDR			

Fig. 1.1 Nameplate OUM 253 (left)

Fig. 1.2 Nameplate OUM 223 (right)

OUM 223 / 253						
<b>Version</b>						
TB	Solids concentration measurement with initial setting for residual concrete water					
TU	Turbidity and solids concentration measurement					
TS	Turbidity and solids concentration measurement, with additional functions (Plus package)					
<b>Power supply</b>						
0	Power supply 230 V AC					
1	Power supply 115 V AC					
2	Power supply 230 V AC, CSA Gen. Purp.					
3	Power supply 115 V AC, CSA Gen. Purp.					
5	Power supply 100 AC					
7	Power supply 24 AC, CSA Gen. Purp.					
8	Power supply 24 V AC/DC					
<b>Measurement output</b>						
0	1 output signal: Turbidity / SS					
1	2 output signals: Turbidity / SS and temp. / turbidity or SS / set value					
<b>Contacts</b>						
05	No additional contacts					
10	2 contacts (limits / PID / timer)					
15	4 contacts (limits / PID / timer / ChemoClean)					
16	4 contacts (limits / PID / timer)					
20	2 contacts with current input (limits / PID / timer)					
25	4 contacts with cleaning, current input (limit / PID / ChemoClean)					
26	4 contacts with timer, current input (limits / PID / timer)					
<b>Additional equipment</b>						
RM1	Initial setting for residual concrete water					
<b>OUM223-</b>	<table border="1" style="display: inline-table; vertical-align: middle;"><tr><td> </td><td> </td><td> </td><td> </td><td> </td></tr></table>					
<b>OUM253-</b>	<table border="1" style="display: inline-table; vertical-align: middle;"><tr><td> </td><td> </td><td> </td><td> </td><td> </td></tr></table>					
<b>complete order code</b>						

**Additional functions of the Plus package (TB / TS )**

- Automatic start of cleaning function, Field F8
- Concentration measurement, function group K

## 2 Safety instructions

### 2.1 Intended application

OUM 223 / 253 is a field-tested and reliable transmitter to determine the turbidity and the solids concentration of fluid media.

OUM 223 / 253 is particularly suitable for use in the following areas:

- Chemicals
- Pharmaceuticals
- Drinking water treatment
- Condensate treatment
- Municipal sewage treatment plants
- Water conditioning

### 2.2 General safety notes

This device has been manufactured for safe operation according to the state of the art in engineering and conforms to the applicable regulations and European standards (see Technical data). It has been designed according to EN 61010-1 and has left the manufacturer's works in perfect condition.

However, if used improperly or for purposes other than the intended purpose, it may be dangerous, e.g. due to incorrect connection.



#### Warning:

- Operating this instrument in any way other than as described in these instructions may compromise the safety and function of the measuring system and is therefore impermissible.
- The notes and warnings in these installation and operating instructions must be strictly adhered to!

### 2.3 Installation, start-up, operation



#### Warning:

- This device may only be installed, connected electrically, commissioned, operated and serviced by properly trained personnel authorized by the system operator.
- The personnel must be familiar with these operating instructions and must adhere to the instructions described therein.
- Make sure that the power supply ratings match the data specified on the nameplate before you connect the instrument to a power source.
- A clearly identified mains disconnecting device must be installed close to the instrument.
- Live components can be touched through the vent slots in the housing and the openings on the rear of the housing. Do not insert any tools, wires, etc., in these slots (OUM 223 only).
- Check that all connections have been properly made before powering up the system!
- Damaged equipment that may be dangerous must not be operated and should be clearly identified as being defective.
- Any troubleshooting of the measuring system is to be performed exclusively by authorized, trained personnel.
- If faults cannot be remedied, the instrument must be removed from service and secured to prevent accidental start-up.
- Repairs not described in these operating instructions may only be performed at the manufacturer's works or by your Service Organization.

## 2.4 Monitoring and safety features

### Safety features

The transmitter is protected against external influences and damage by the following design measures:

- Rugged housing
- Degree of protection provided by enclosure: IP 65 (OUM 253)
- UV resistance

### Monitoring features

In the event of a system error or power failure, an alarm condition is signalled via a fail-safe fault signalling contact.

## 2.5 Immunity to interference

This instrument has been tested according to the applicable European standards for industrial applications with regard to electromagnetic compatibility. It is carefully protected against electromagnetic interference by constructive design measures.



### Warning:

The specified immunity to interference only applies for devices connected as outlined in these operating instructions.

## 2.6 Declaration of conformity

The transmitter OUM 223/253 has been developed and manufactured in accordance with currently valid European standards and directives.

The manufacturer certifies the compliance with the standards by using the **CE** sign.

### 3 Installation

The following procedure should be followed for a complete measuring system installation:

- Installation or attachment transmitter (see chap. 3.3)
- Selection and connection of cable and sensor (see chap. 3.4, 3.5 and 9)
- Installation is followed by start-up (see chap. 5).

#### 3.1 Measuring system

The complete measuring system comprises:

Optional:

- The OUM 223 or OUM 253 transmitter
- A sensor with integrated temperature sensor and a permanently attached cable
- An installation assembly
- Extension cable OYK 8
- Junction box VBM or RM

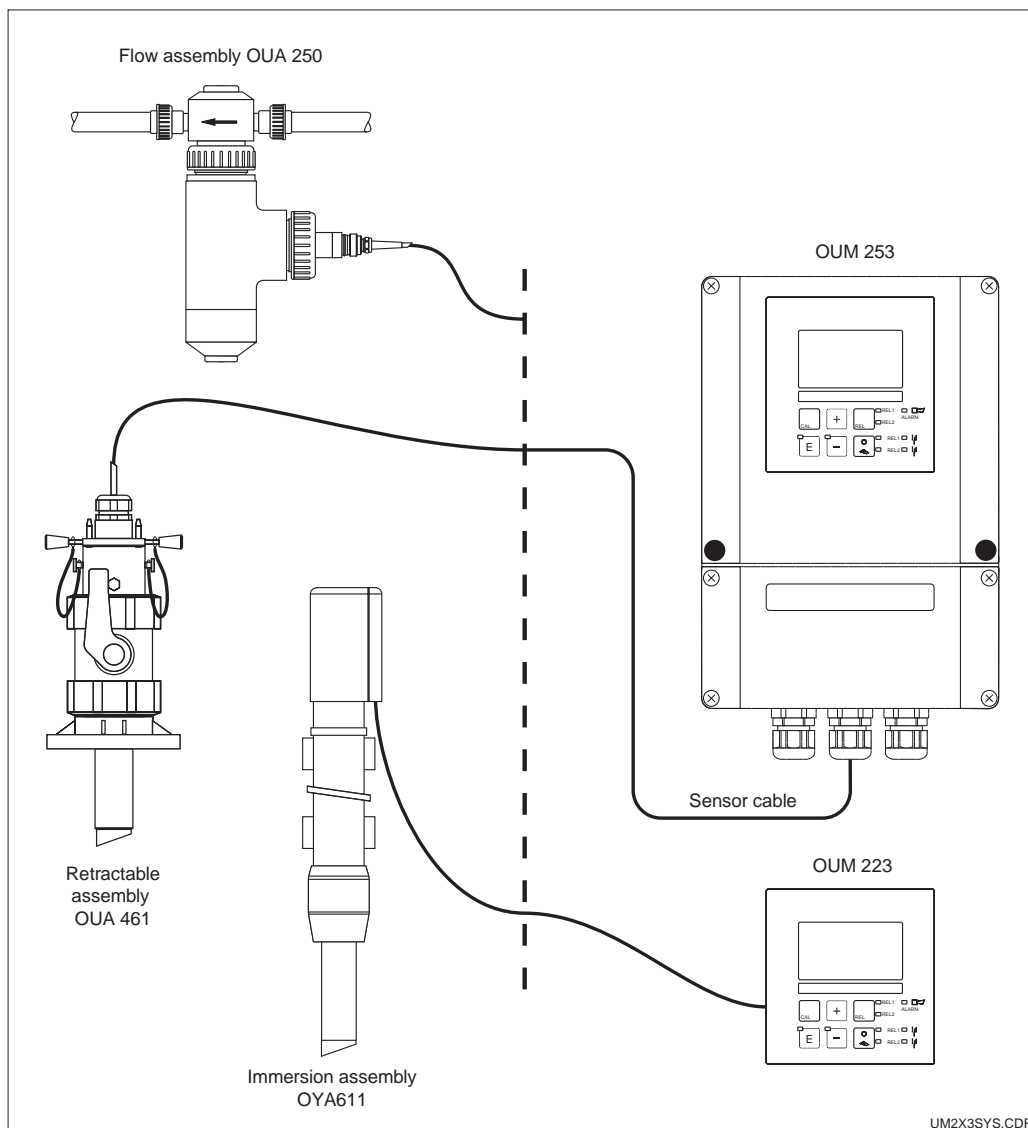

Complete measuring system consisting of OUM 223 / 253 with measuring cable, assembly and turbidity sensor

Fig. 3.1

UM2X3SYS.CDR

### 3.2 Dimensions

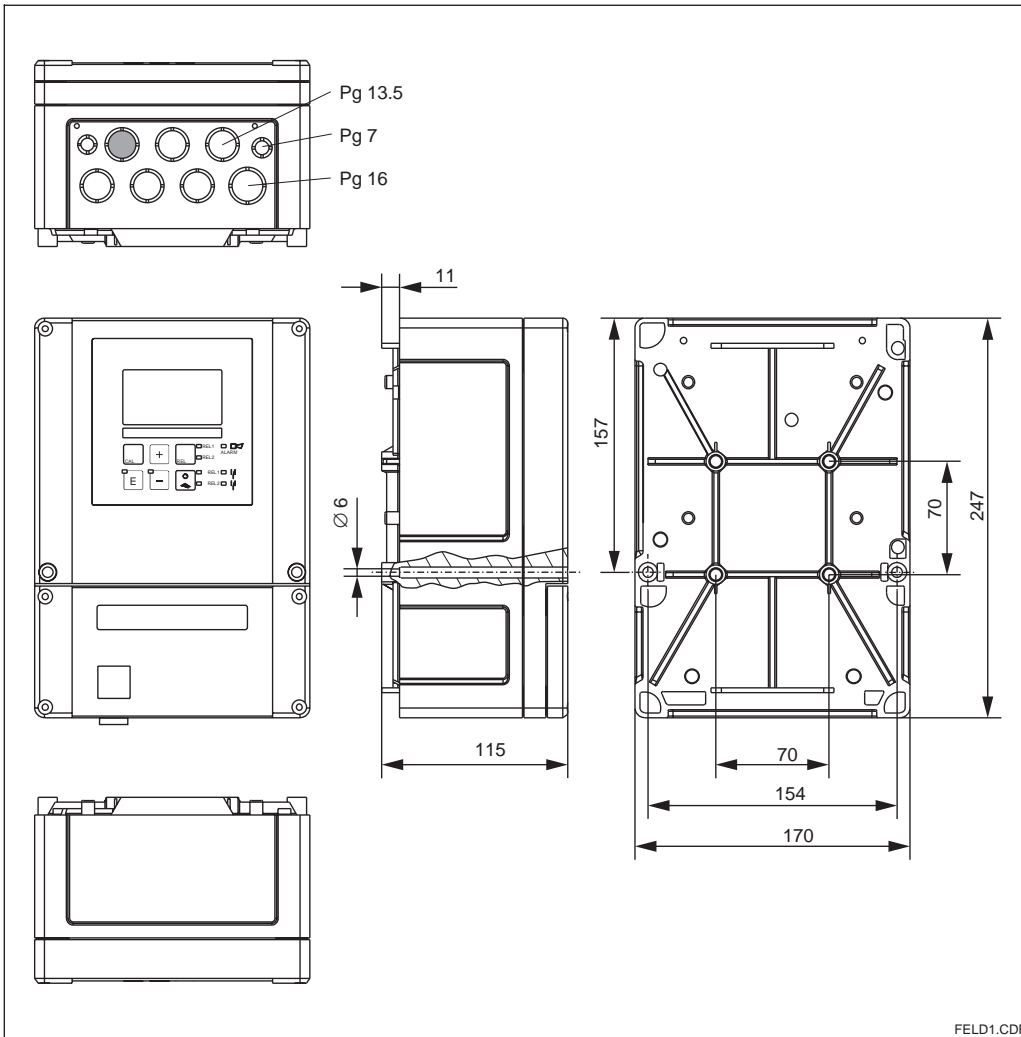

FELD1.CDR

Fig. 3.2 Dimensions of OUM 253



**Note:**

There is a hole in the punching for Pg 16 cable entry. It serves as a pressure balance during air freight dispatching. Make sure that there is no moisture penetrating into the housing before cable installation. After cable installation, the housing is completely tight.

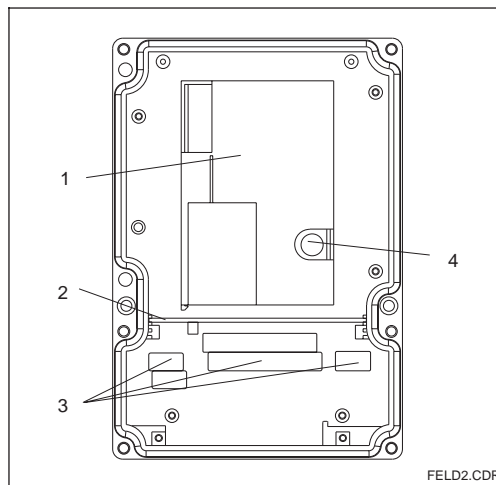

FELD2.CDR

Inside of housing of OUM 253  
 1 Removable electronics box  
 2 Partition plate  
 3 Terminal blocks  
 4 Fuse

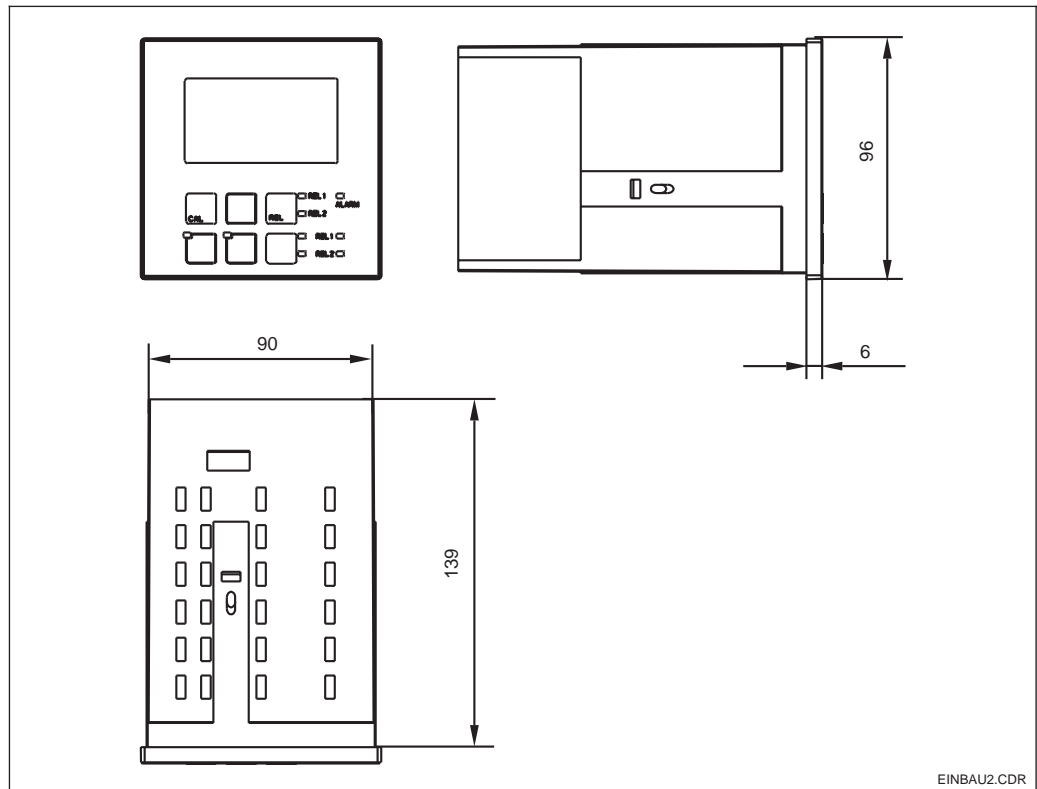
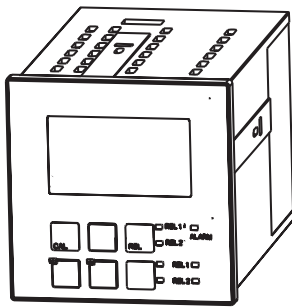

Fig. 3.4 OUM 223 panel-mounted version

EINBAU2.CDR

### 3.3 Mounting

#### 3.3.1 Field instrument

Several mounting options are available for the transmitter in the fieldinstrument version:

- Post mounting on cylindrical pipes
- Post mounting on a square post
- Wall mounting with fastening screws

Weather protection cover OYY 101 can be used for outdoor installation in conjunction with all mounting variants.



**Note:**

If installed outdoors, weather protection cover required.

#### Weather protection cover OYY 101

Weather protection cover for outdoors installation, to be mounted on field instrument; material: stainless steel SS 304

For post or pipe installation, the post mounting kit is additionally required.

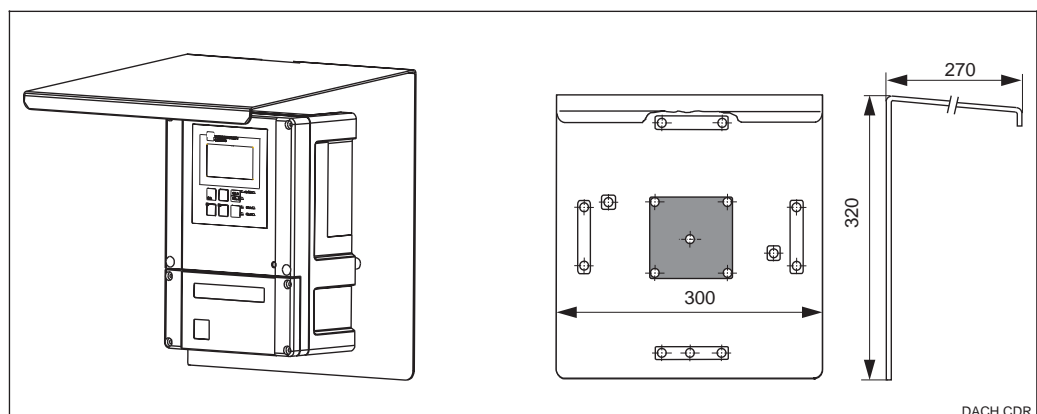

Fig. 3.5 Weather protection cover for field instruments

DACH.CDR

**Post mounting kit**

Mounting kit for installation of field housing on horizontal and vertical pipes (max. Ø 60 mm); also aids fixing of weather protection cover.  
Material: stainless steel SS 304

**Universal mounting post ÓYY 102**

Square tube for mounting of transmitter;  
material: stainless steel SS 304

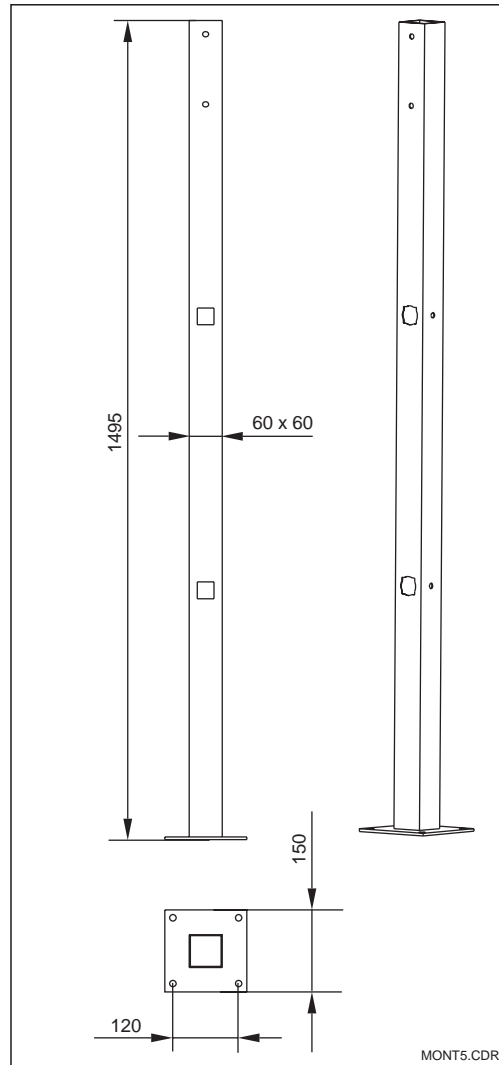
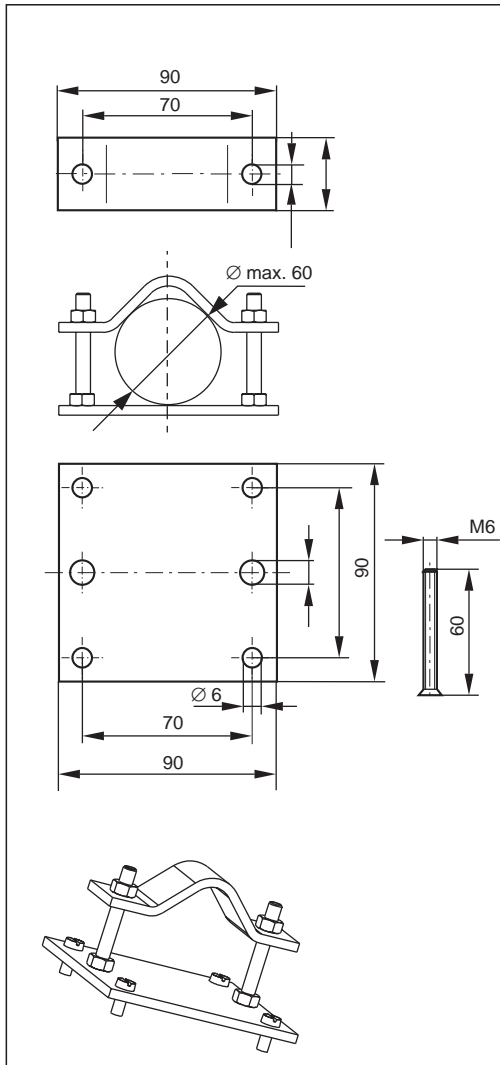

left:  
Mounting kit  
for post mounting on  
cylindrical pipes

right:  
Square mounting post

Fig. 3.6

3.3.2 Mounting examples

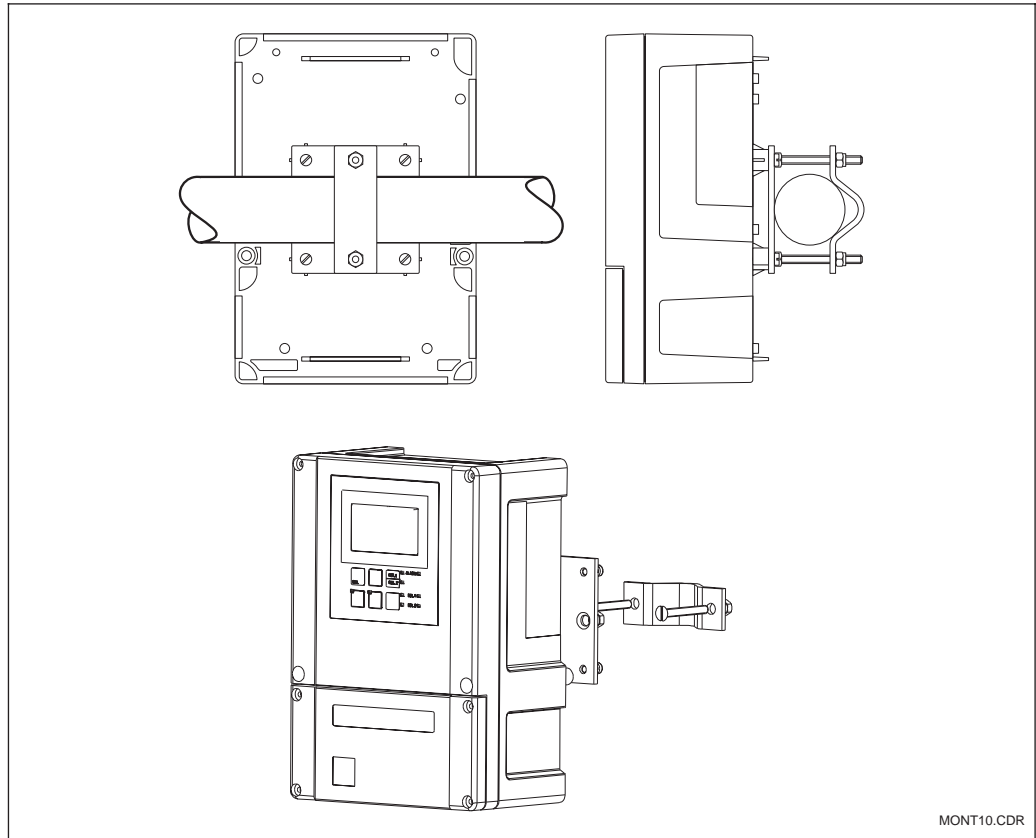
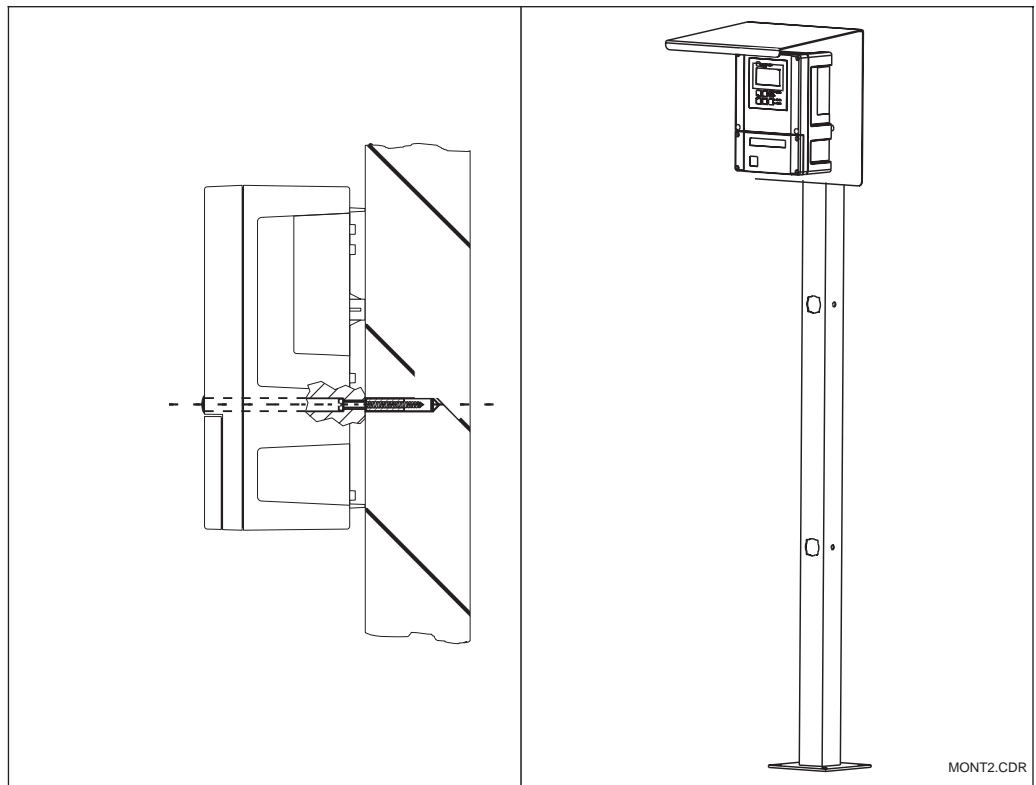

Fig. 3.7 Pipe mounting of field instrument



Field instrument

*left:*  
Wall mounting

*right:*  
Mounting with  
universal post and  
weather protection cover

Fig. 3.8

**3.3.3 Panel-mounted instrument**

The instrument is attached using the supplied tensioning screws (see Fig. 3.9).  
The required overall installation depth is approx. 165 mm.

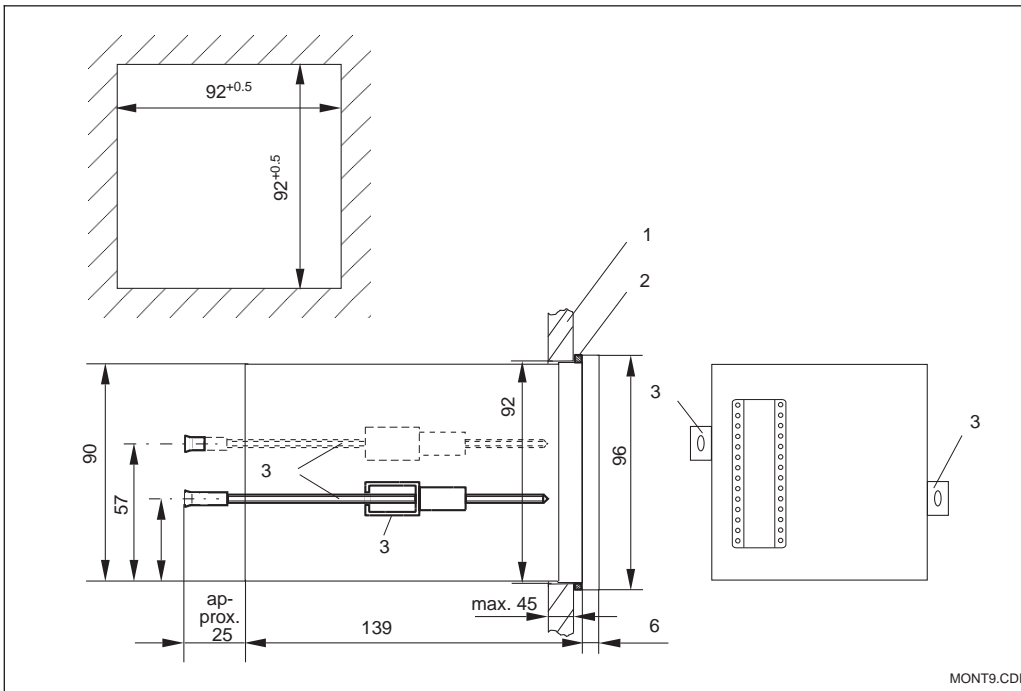

Attachment of panel-mounted device  
 1 Wall of control cabinet  
 2 Gasket  
 3 Tensioning screws

### 3.4 Electrical connection

#### Connection diagram

The connection diagram depicted in Fig. 3.10 shows the instrument connections for turbidity sensors OUS 31 or OUS 41. The connection of the varrious sensors is shown in more detail in Figs. 3.13 and 3.14.

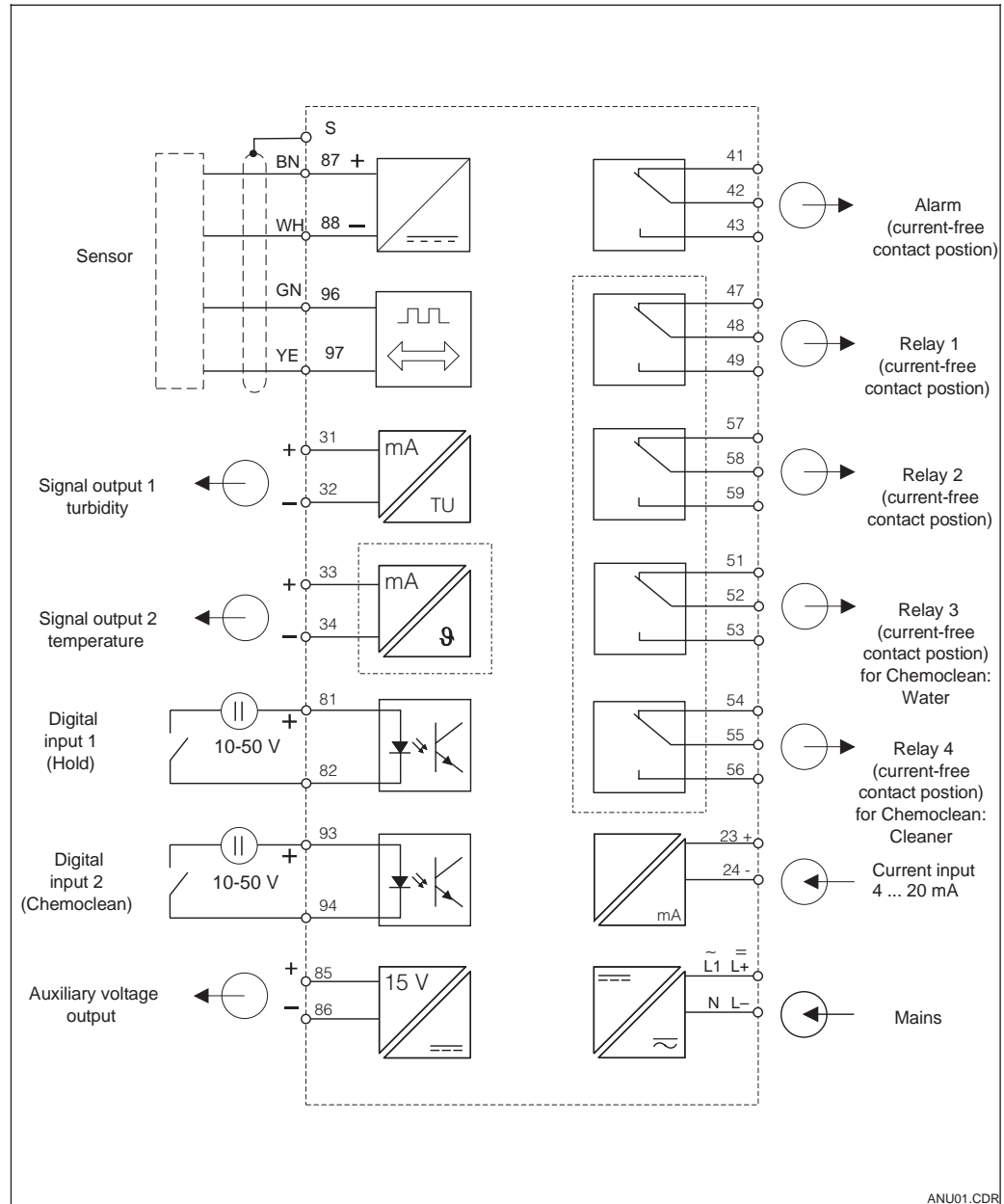

Fig. 3.10 Electrical connection of OUM 223/253 with full wiring

ANU01.CDR



**Note:**

- The instrument has protection class II and is generally operated without protective earth connection.
- Mains supply voltage fluctuations should not exceed ten percent of the nominal supply voltage.
- 24V AC/DC models must be supplied from an energy limiting SELV source in accordance with dir. IEC 1010.1 Annex H.



**Note:**

Please label the sensor terminal block with the enclosed sticker.



**Caution!**

- Terminal designated as NC may not be switched.
- Undesignated terminals may not be switched.

**Connections of field instrument**

For connection, the measuring cables are introduced through the cable glands on the field instrument and connected according to the diagrams in figures 3.10 and 3.11.

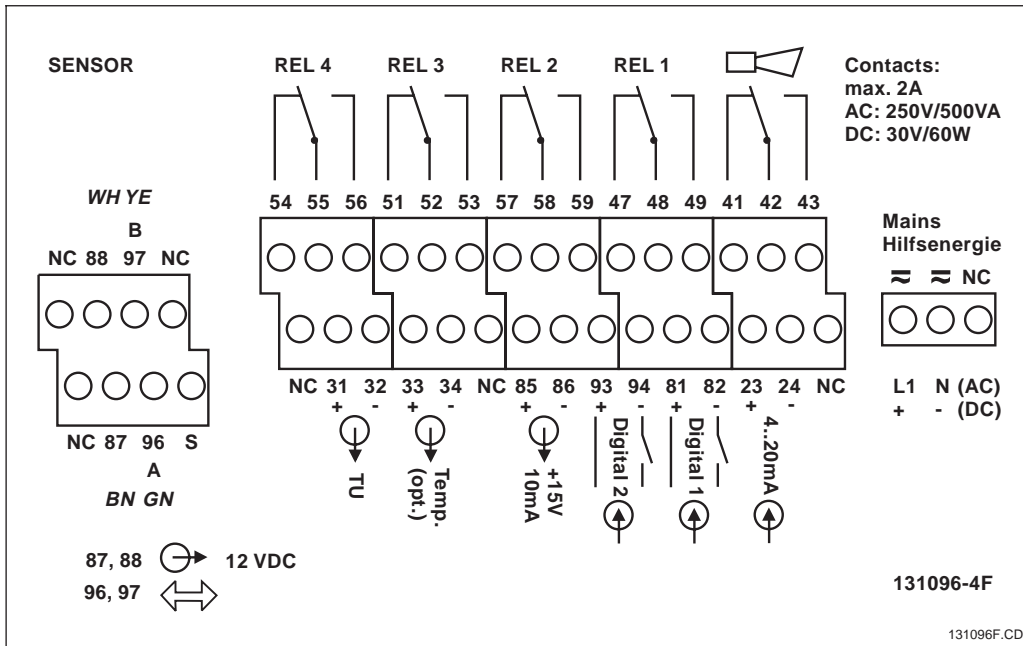

Fig. 3.11 Connection compartment sticker for field instruments OUM 253; Instrument status: de-energised

**Connections of panel-mounted instrument**

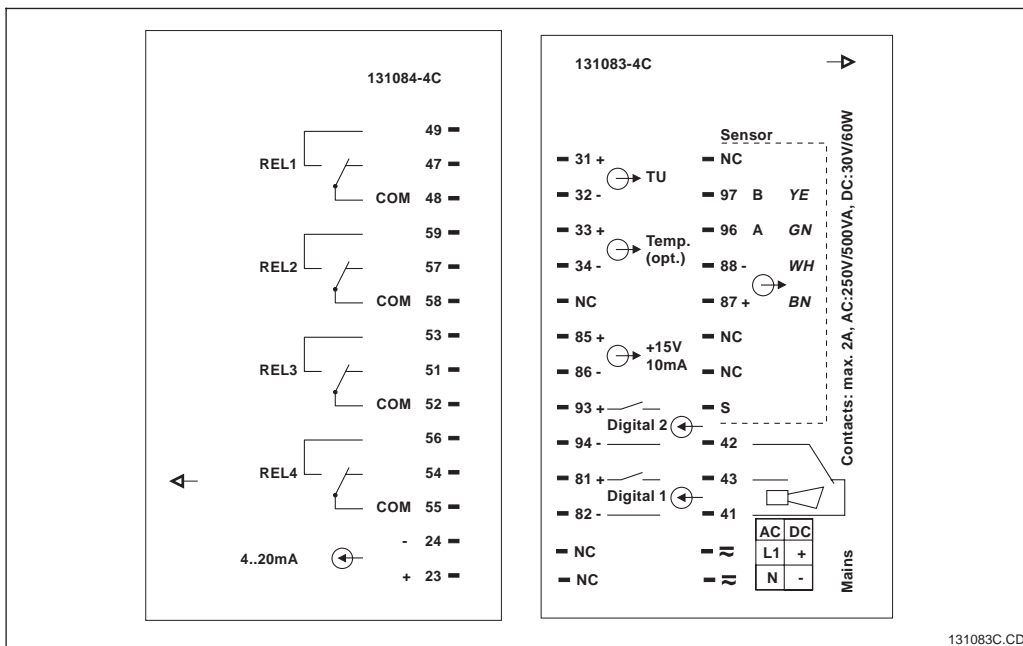

Fig. 3.12 Connection compartment sticker for panel-mounted instruments OUM 223

### 3.5 Sensor installation and measuring cable connection

#### Measuring cable connection

The terminal block is located in a separate connection compartment which is accessible by opening the plastic cover. Remove the pre-pressed knock-outs for cable entry.

The sensor is connected via a multiple-core, special screened cable which is completely terminated and permanently connected. Use a junction box, e.g. VBM to extend the measuring cable. Termination instructions are supplied with the measuring cables.



**Note:**

- Protect cable ends and terminals against moisture to prevent inaccurate measurement!
- For further information on cables and junction boxes refer to chap. 9 Accessories.

Measuring cable requirements		
Sensor type	Cable	Extension
Turbidity sensor OUS 31, OUS 41	Non-detachable cable on sensor	VBM box + OYK 8
<b>Maximum cable length</b>		
OUS 31 / OUS 41	max. 200 m using OYK 8	

#### Structure and termination of the measuring cable

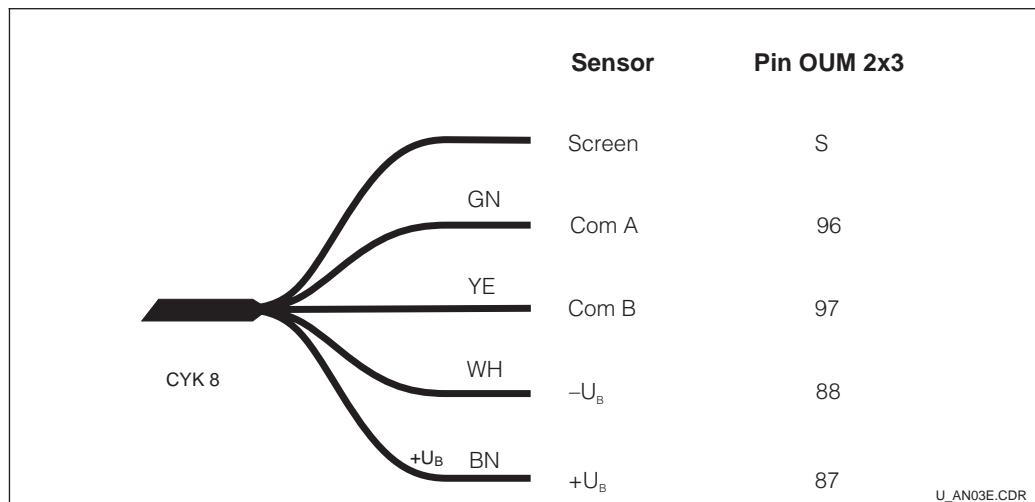

Fig. 3.13 Structure of the special measuring cable OYK 8

Connection examples

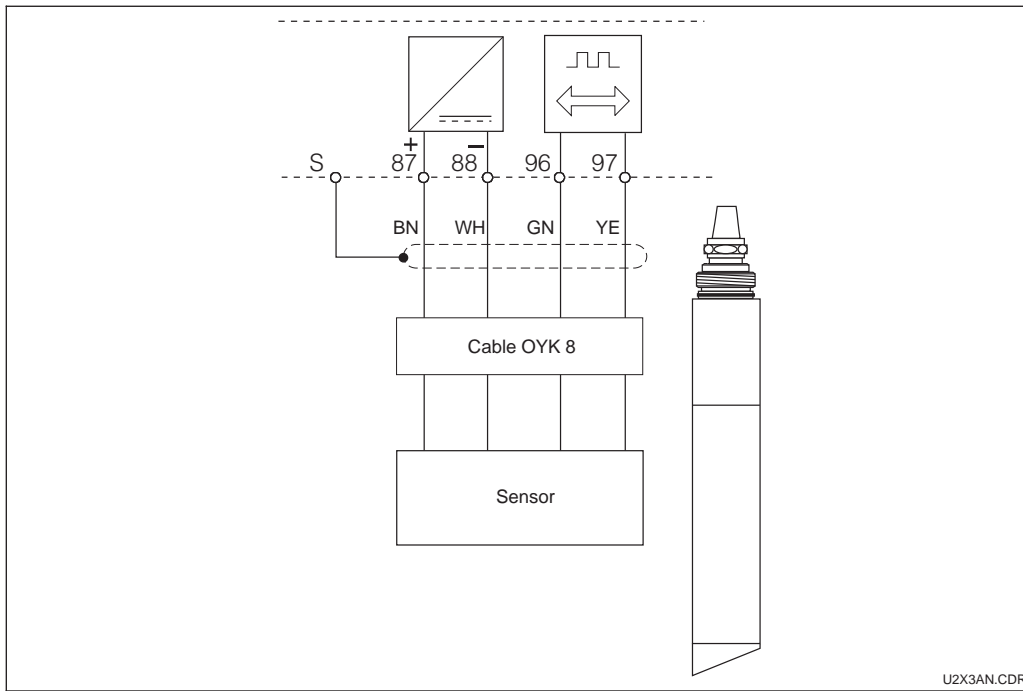

Fig. 3.14 Connection of turbidity sensors OUS 31 and OUS 41

## 4 Operation

### 4.1 Operator interface

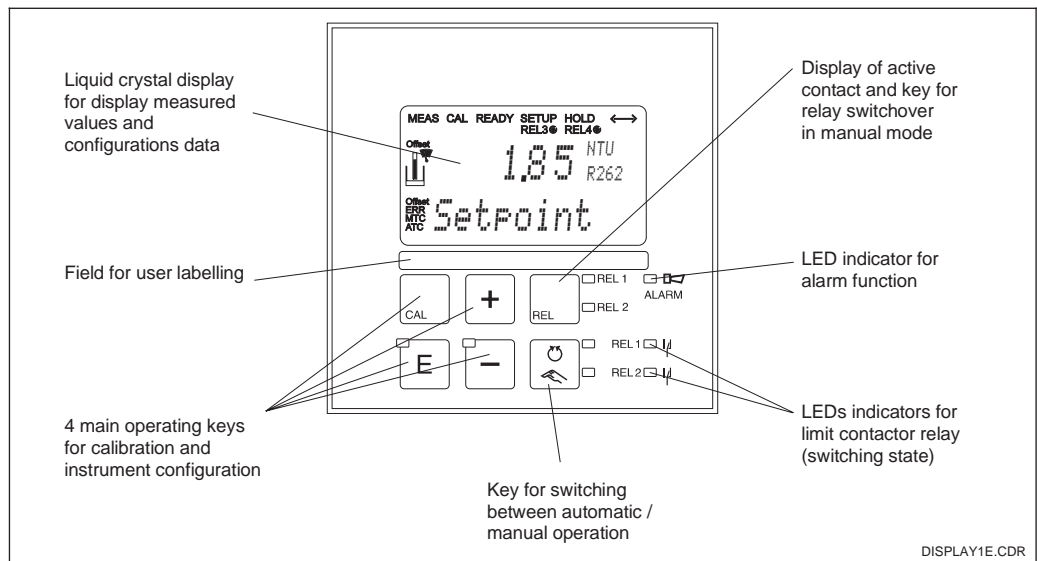





Fig. 4.1 Operating elements

### 4.2 Display

#### LED Display

 Indication of current operating mode "Auto" (green LED) or "Manual" (yellow LED)

 Indication of controlled relay in "Manual" mode (red LED)

REL1  Indicates the state of relays 1 and 2  
 LED green: measured value within permissible limits, relay inactive  
 REL2  LED red: measured value outside permissible limits, relay active

ALARM  Alarm indication e.g. for continuous limit violation, temperature sensor failure or system error (see error list chap. 7)

#### Liquid crystal display

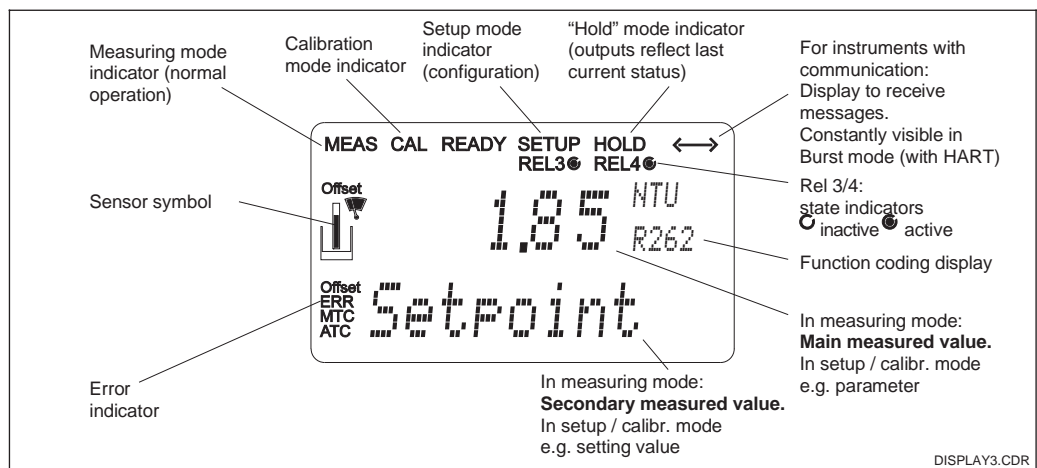

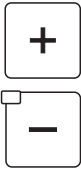

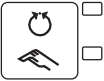

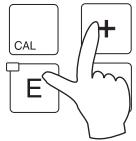
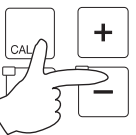
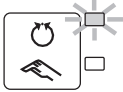

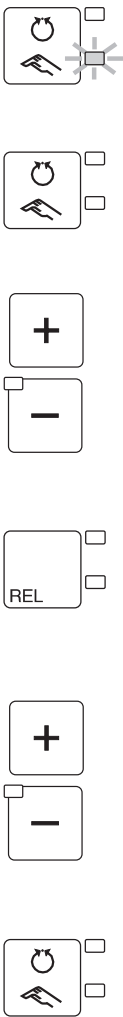

Fig. 4.2 Liquid crystal display

### 4.3 Function of the operating keys

	<p><b>CAL key</b>                  When the CAL key is pressed, the instrument prompts for the calibration access code:                  Code 22 for calibration                  Code 0 or any code for calibration data checking.                  Press the CAL key to acknowledge the calibration data or to proceed within the calibration menu.</p>
	<p><b>ENTER key</b>                  The ENTER key has the following functions:                  Opens the Setup menu in Measurement mode                  Stores (acknowledges) entered data in Setup mode.                  Moving on within the function groups.</p>
	<p><b>PLUS key and MINUS key</b>                  The PLUS and MINUS keys have the following functions:                  Selection of function groups                  Setting of parameters and numeric values                  Relay operation in manual mode (see chap. 4.4).                  Pressing the <b>PLUS key</b> allows you to switch between the current output in % and mA.  <b>Repeatedly pressing the PLUS key</b> displays the following settings in sequence as secondary measured values:                  1. Temperature display in °F                  2. Hiding the temperature display                  3. Current input signal in %                  4. Current input signal in mA                  5. Measured value display in FNU or NTU (uncompensated value without installation adjustment, offset and slope, referred to data set 1)  <b>Repeatedly pressing the MINUS key</b> displays the errors:                  1. The current errors are displayed one after the other (max. 10)                  2. After all the errors are displayed, the standard display is unhidden.                  In function group F, you can define an alarm for each error code separately.</p>
	<p><b>REL key</b>                  The REL key toggles between the relay and manual cleaning start in manual mode. In automatic mode you can output the corresponding switch-on points (limit contactor) or set points (PID controller) when pressing the REL key. Pressing the PLUS key allows you to display the settings of the following relay. Press the REL key to return to measuring mode (automatic return after 30s).</p>
	<p><b>AUTO key</b>                  The AUTO key is used to toggle between the automatic and manual modes of operation.</p>
	<p><b>Escape function</b>                  Press the PLUS and MINUS keys simultaneously to return to the main menu. Press the PLUS and MINUS keys again to return to measuring mode.</p>
	<p><b>Locking the keypad</b>                  Pressing the PLUS and ENTER keys simultaneously for minimum 3s locks the keypad against unintentional entries. However, all settings can still be read. The code prompt displays the code 9999.</p>
	<p><b>Unlocking the keypad</b>                  Press the CAL and MINUS keys simultaneously for minimum 3s to unlock the keypad. The code prompt displays the code 0:</p>

### 4.4 Auto / manual mode of operation

	<p><b>Auto mode</b> In this mode of operation, the relays and the wiper are controlled by the transmitter.</p>
	<p><b>REL key</b> In manual mode, the REL key is used to select one of the relays or the cleaning function present in the instrument.</p>
	<p><b>Switch to manual mode</b> The instrument is switched to manual mode for relay or wiper setting by pressing the following keys:</p> <p>Press AUTO key.</p> <p>Enter code 22. Confirm with ENTER key.</p> <p>Select relay or wiper function. Press the REL key to toggle between the relays or the wiper. The display shows the selected relay and the switching status (ON / OFF) in the second line. In manual mode, the measuring value is continuously displayed (e.g. for monitoring during dosage).</p> <p>Set the relays or the wiper. Switch on with PLUS, switch off with MINUS. The relay or wiper state remains in effects until it is actively reset.</p> <p>Press AUTO key for returning to the measuring mode. All relays are controlled by the transmitter again.</p>



**Note:**

- Enable the manual mode by entering setup code "22".
- Hardware locking in the manual mode is not possible.
- The operating mode is retained even after a power failure.
- The manual settings remain in effect until they are actively reset.
- The manual mode takes precedence over any other automatic function (hold).
- Error code E102 is signalled in the manual mode.

## 4.5 Operating concept

### 4.5.1 Operating modes

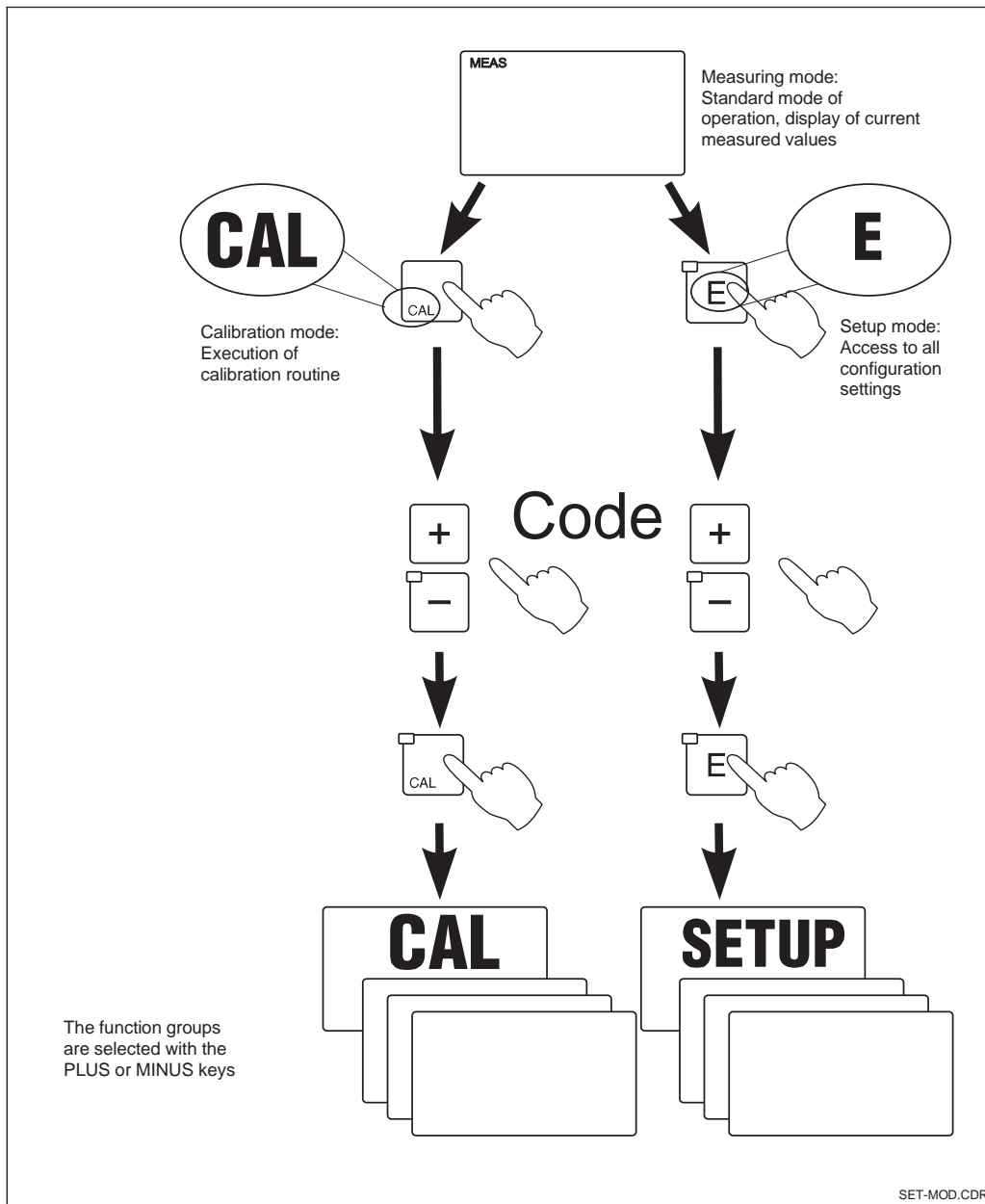

Fig. 4.3 Description of possible operating modes



**Note:**

- Remains in setup mode for approx. 15 mins., the system automatically returns to measuring mode. An active hold function (Hold at Setup) is then reset.

### 4.5.2 Access codes

All instrument access codes are fixed, i.e. they cannot be modified. When the instrument requests the access codes, it recognises the difference between codes (cf. Fig. 5.3):

- **CAL key + Code 22:** Access to Calibration and Offset menus.
- **ENTER key + Code 22:** Access to the Configuration menus, allowing configuration and user-specific settings.
- **PLUS + ENTER keys + Code 9999:** Locks the keypad.
- **CAL + MINUS keys + Code 0:** Unlocks the keypad.
- **CAL or ENTER key + any Code:** Access to Read mode, i.e. all settings can be read but not changed.

### 4.5.3 Menu structure

The configuration and calibration functions are arranged in a menu structure by function groups.

The function groups are selected in the setup mode with the PLUS and MINUS keys. The ENTER key is used to move from one function to the next within a function group. The PLUS and MINUS keys are used for option selection and editing. Selections must be confirmed by pressing the ENTER key. This also moves the cursor to the next function.

Pressing the PLUS and MINUS keys at the same time terminates programming (return to main menu).



**Note:**

- If a change is made but not confirmed by pressing the ENTER key, the previous setting is retained.
- See the appendix of these operating instructions for an overview of the menu structure.

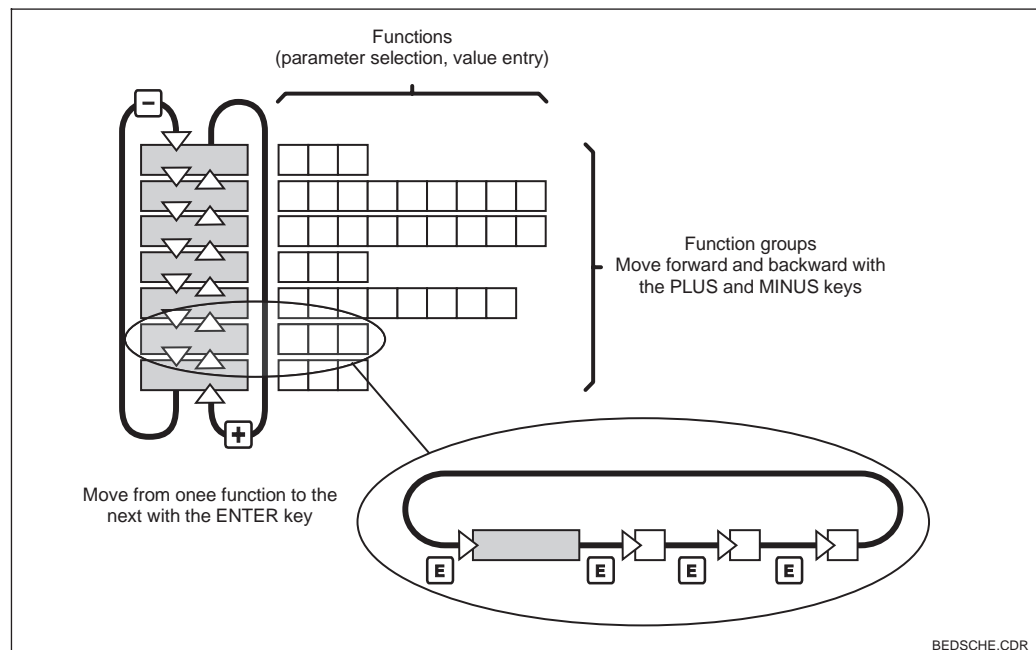

Fig. 4.4 Schematic representation of the menu structure

#### 4.5.4 Hold function: “Freezes” the outputs

The current output is “frozen” in the setup mode and during calibration, i.e. the last current value is constantly output. HOLD appears on the display. In case of steady control (4... 20 mA) on current output 2, it is set to 0/4 mA during Hold.

**Note:**

- Hold settings can be found in chap. 5.6, function S2.
- During automatic operation, all contacts will go to their normal positions.
- An active hold has priority over all other automatic functions.
- With every hold, the I component of the controller is set to zero.
- A possibly accumulated alarm delay is reset to “0”.
- The hold function can also be activated externally via the hold input (see connection diagram in Fig. 3.10; digital input 1).
- The manual hold (field S3) remains active even after a power failure.

## 5 Instrument configuration

After power-up the instrument performs a self-test and then enters the measuring mode.

Now it can be configured and calibrated for the first time. The values set by the user are kept even in the event of a power failure.

The following function groups are available on the transmitter (the groups that are only available in the Plus package are marked accordingly in the functional descriptions):

### Setup mode

- SETUP 1 (A) see chap. 5.2.1
- SETUP 2 (B) see chap. 5.2.2
- CURRENT INPUT (Z) see chap.
- CURRENT OUTPUT (O) see chap. 5.3
- ALARM (F) see chap. 5.5.1
- CHECK (P) see chap. 5.5.2
- RELAY (R) see chap. 5.5
- CONCENTRATION (K) see chap. 5.6
- SERVICE 1 (S) see chap. 5.7
- SERVICE 2 (E) see chap. 5.8
- INTERFACE (I) see chap. 5.9

### Calibration and offset mode

- CALIBRATION (C) see chap. 5.10
- OFFSET (V) see chap. 5.11
- SLOPE (N) see chap.

Fig. 5.1 Example of display in setup mode

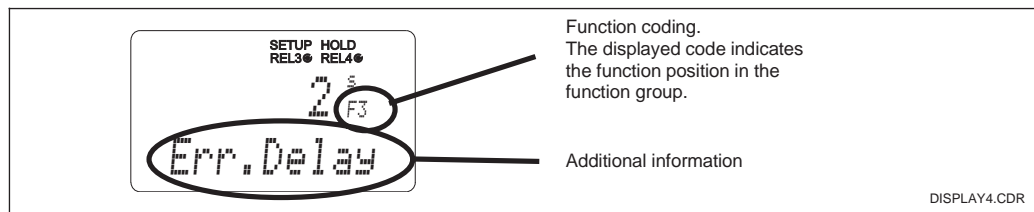
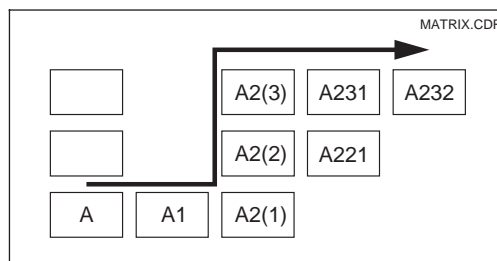

Fig. 5.2 Function coding



Selecting and locating functions is facilitated by a code displayed for each function in a special display field. The structure of this coding is given in Fig. 5.2. The first column indicates the function group as a letter (see group designations). The functions in the individual groups are counted from the top to the bottom and from the left to the right.

**Factory settings**

When the instrument is switched on for the first time, the factory settings are in effect. The following table provides an overview of all major settings. Please refer to the descriptions of the individual functions in chapter 5 for all other factory settings (the factory setting is printed in **bold** type).

Function	Factory setting
<b>Type of measurement</b>	Turbidity in FNU, temperature in °C
<b>Temperature offset / turbidity offset</b>	0 °C 0 FNU
<b>Limit 1</b>	9999 FNU
<b>Contact function of limit contactor 1</b>	MAX contact without delay
<b>Limit 2</b>	9999 FNU
<b>Contact function of limit contactor 2</b>	MAX contact without delay
<b>Current outputs 1 and 2*</b>	4 ... 20 mA
<b>Current output 1: measured value for 4 mA signal current</b>	0 FNU
<b>Current output 1: measured value for 20 mA signal current</b>	10.0 FNU
<b>Current output 2: temperature value at 4 mA signal current*</b>	-5.0 C
<b>Current output 2: temperature value for 20 mA signal current*</b>	100.0 °C
<b>Measured value damping</b>	10
<b>Calibration data set</b>	no. 3
<b>Wiper controller</b>	Off

\* if equipped accordingly

**Alarm contacts**

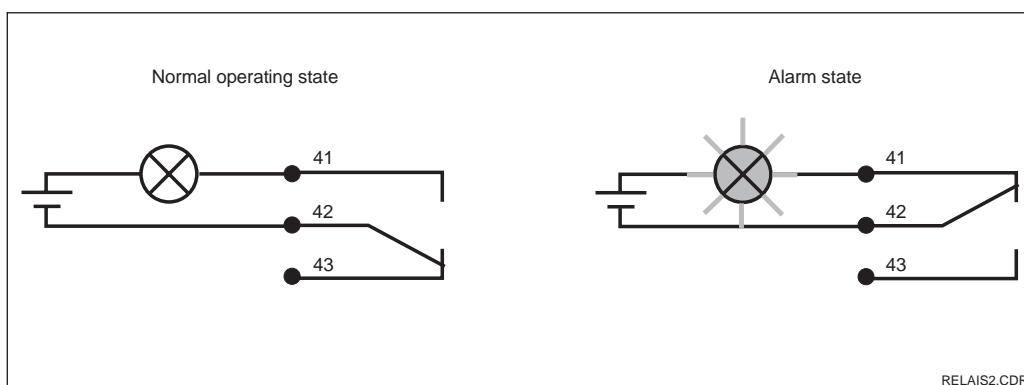

Recommended fail-safe circuit for the alarm contact

Fig. 5.3

Normal operating state:

- Instrument in operation
- No error message available (Alarm LED off)

→ Relay picked up  
→ Contact 42/43 closed

Alarm state:

- Error message available (Alarm LED red) or
- Device defective or voltage-free (Alarm LED off)

→ Relay dropped out  
→ Contact 41/42 closed

## 5.1 Start-up

After switching the instrument on, make the following settings to the specified function groups:

- **Function group SERVICE (S)**  
S1: Select language and exit function group (not required for English).
  - **Function group SETUP 1 (A)**  
Adjust all parameter in this group, see chap. 5.2.1.
  - **Function group SETUP 2 (B)**  
Make all settings in this group, see chap. 5.2.2.
- Other configuration options are explained in the chapters to follow for each menu.

## 5.2 System configuration

The system is configured using the function groups SETUP 1 and SETUP 2. Here, select the measurement type, the sensor and the settings for the temperature measurement. All the parameters in these two function groups are to be configured to avoid measuring errors or failure to measure at all.

### 5.2.1 Setup 1 (Turbidity)

For access to the SETUP menu, please enter Code 22.

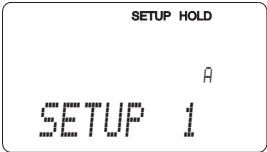
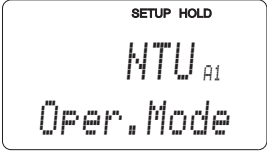
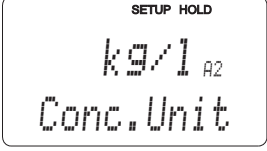
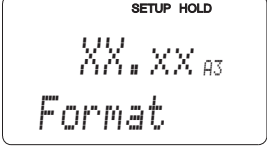
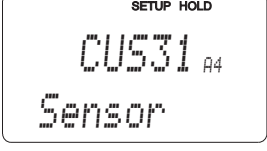
Coding	Field	Selection or range Factory setting (bold)	Display	Info
A	Function group SETUP 1			Initial display in function group SETUP 1.
A1	Operation mode selection	<b>NTU</b> FNU ppm mg/l g/l % <i>spec.</i>		Any change in operating mode causes an automatic reset of userdefined settings. The offsets for turbidity and temperature are reset to zero.
A2	<i>Selection of display unit</i>	<b>kg/l</b> % <i>t/m3</i> <i>none</i>		<i>A2 only accessible, if A1 = spec.</i>
A3	<i>Selection of display format</i>	<b>XX.xx</b> <i>X.xxx</i> <i>XXX.x</i> <i>XXXX</i>		<i>A3 only accessible, if A1 = spec.</i>
A4	Connected sensor is displayed	CUS31 CUS41		The transmitter automatically detects which sensor is connected.

Factory settings are printed in **bold** face;  
base version does not include functions in *italic*.

Coding	Field	Selection or range Factory setting (bold)	Display	Info
A5	Enter measured value damping	<b>10</b> 1 ... 60		Measured value damping causes averaging over the specified number of individual measured values. It is used, for example, to stabilise the display with applications that fluctuate a great deal. There is no damping if "1" is entered.

### 5.2.2 Setup 2 (Temperature)

Coding	Field	Selection or range Factory setting (bold)	Display	Info
<b>B</b>	<b>Function group SETUP 2</b>			Initial display in function group SETUP 2.
B1	Switch wiper controller on or off	<b>off</b> on auto		If "auto" is selected, the wiper is operated in combination with a cleaning function via timer / Chemoclean ("wipe and clean"). In this case B2 and B3 are not applicable.
B2	Enter operation period of wiper	<b>30 s</b> 3 ... 999 s		
B3	Enter pause time between two wiping cycles	<b>120 min</b> 1 ... 7200 min		
B4	Selection of calibration data set to be used	<b>3</b> 1 ... 3		There are 3 calibration data sets stored in every operation mode (A1). Data set 1 cannot be changed (see chap. 5.10).
B5	Copy data sets	<b>no</b> 1 -> 2 1 -> 3 2 -> 3 3 -> 2		Data set 1 cannot be changed (factory setting). However, it can be used as a basic for a customer calibration data set. To work with the copy of the data set, select the data set in field B4.

The factory settings are printed in **bold**; functions printed in *italics* are not available in the basic version.

Coding	Field	Selection or range Factory setting (bold)	Display	Info
B6	Display measured value with reflection adaptation?	<b>yes</b> no	<div style="border: 1px solid black; padding: 5px; text-align: center;">                     SETUP HOLD                      YES <sub>B6</sub>                      refl. adi.                 </div>	With the CUS 31 / 41: displays the measured value with or without assembly adaptation (reflection). Only effective in NTU, FNU, ppm, mg/l ranges).
B7	Enter corrected temperature of the temperature sensor	<b>Current measured value</b> -5.0 ... 100.0 °C	<div style="border: 1px solid black; padding: 5px; text-align: center;">                     SETUP HOLD                      0.0 °C <sub>B7</sub>                      RealTemp                 </div>	This entry can be used to calibrate the temperature sensor to an external measurement.
B8	Enter temperature difference (offset)	<b>Current offset</b> -5,0 ... 5,0 °C	<div style="border: 1px solid black; padding: 5px; text-align: center;">                     SETUP HOLD                      0.0 °C <sub>B8</sub>                      Temp. Off's                 </div>	The difference between the temperatures measured and entered is displayed.
B9	Enter gas bubble barrier	<b>3.0%</b> 0.1 ... 100%	<div style="border: 1px solid black; padding: 5px; text-align: center;">                     SETUP HOLD                      3.0 % <sub>B9</sub>                      GasBubble                 </div>	Compensates slow gas bubble formation, which may arise from small amounts of dissolved gas in the medium. 0.1%= no formation of gas bubbles 100%= strong tendency to gas bubble formation

Factory settings are printed in **bold** face;  
base version does not include functions in *italic*.

### 5.3 Current input

This function group offers two independent application solutions, provided that the current output of an external measured quantity, e.g. flow meter, is connected to the 4 ... 20 mA input of OUM 223 / 253. The following assignments then apply:

	Flow in main stream	Current signal in mA	Current input signal in %
<b>Lower range limit current input</b>	Lower setting value flow meter	<b>4</b>	<b>0</b>
<b>Upper range limit current input</b>	Upper setting value flow meter	<b>20</b>	<b>100</b>

#### 5.3.1 Monitoring the flow rate in the main stream

This arrangement is highly practical when the sample stream flowing through the flow assembly is totally independent of the flow rate in the main stream. This permits the signalling of an alarm state in the main stream (flow rate too low or totally stopped) and trigger a dosing switch-off, even if the measuring water stream is retained due to the installation configuration.

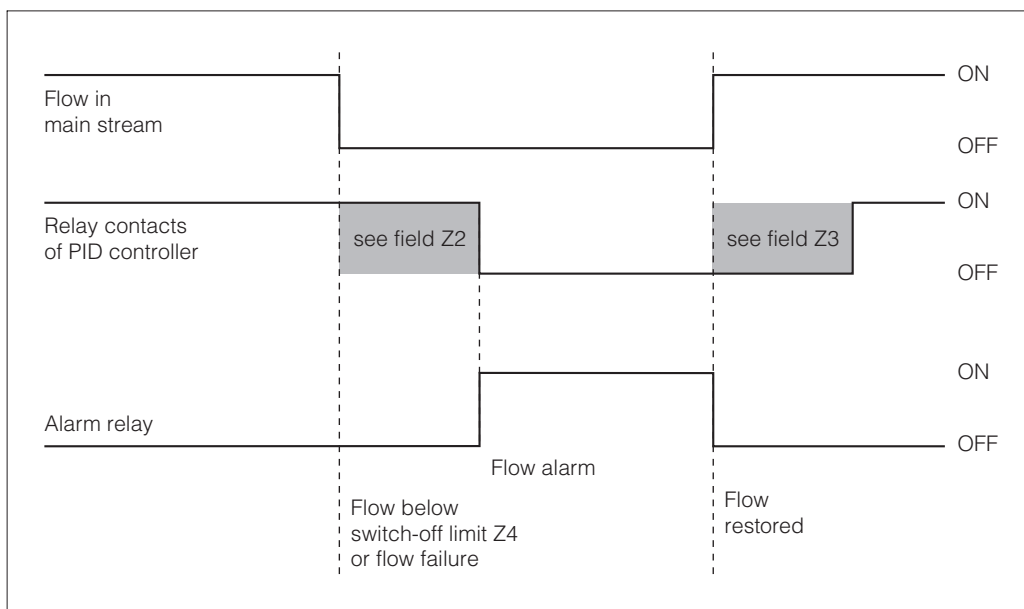
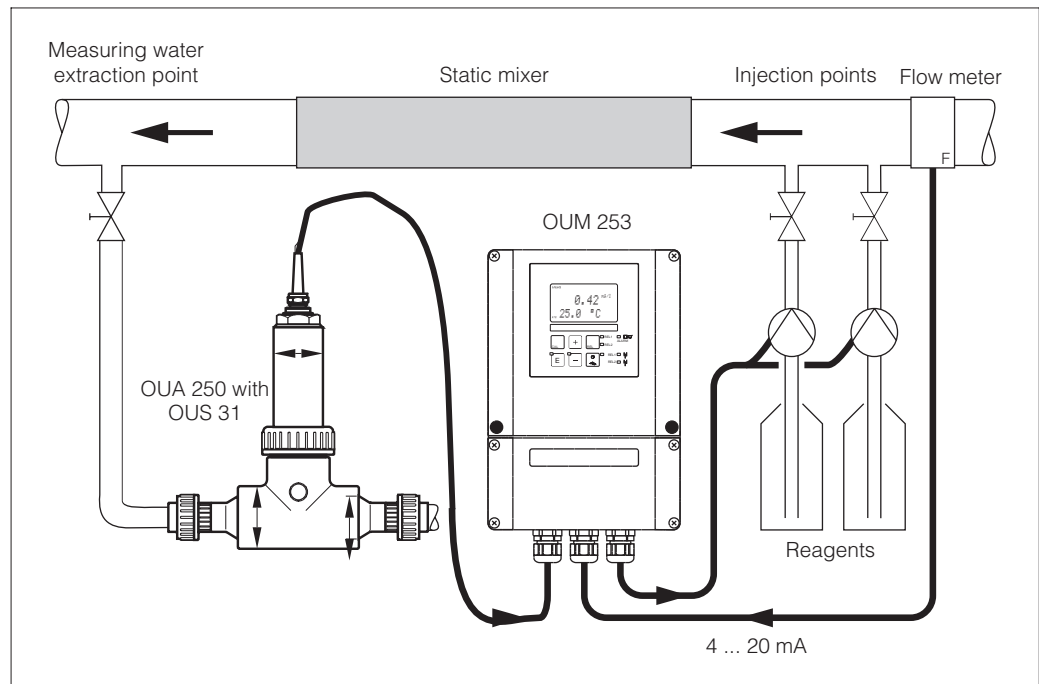

Fig. 5.4

Alarm signalling and dosing switch-off by the main stream

### 5.3.2 Feedforward control to PID controller

In processes with very short response times it may be practical to apply the flow rate to the controller, if the flow rate fluctuates, in order to optimise the control process.



Arrangement example for feedforward control of the flow rate in the main stream to the PID controller(s)  
Fig. 5.5

Feedforward control is a multiplying function as depicted in the below figure (factory setting as example):

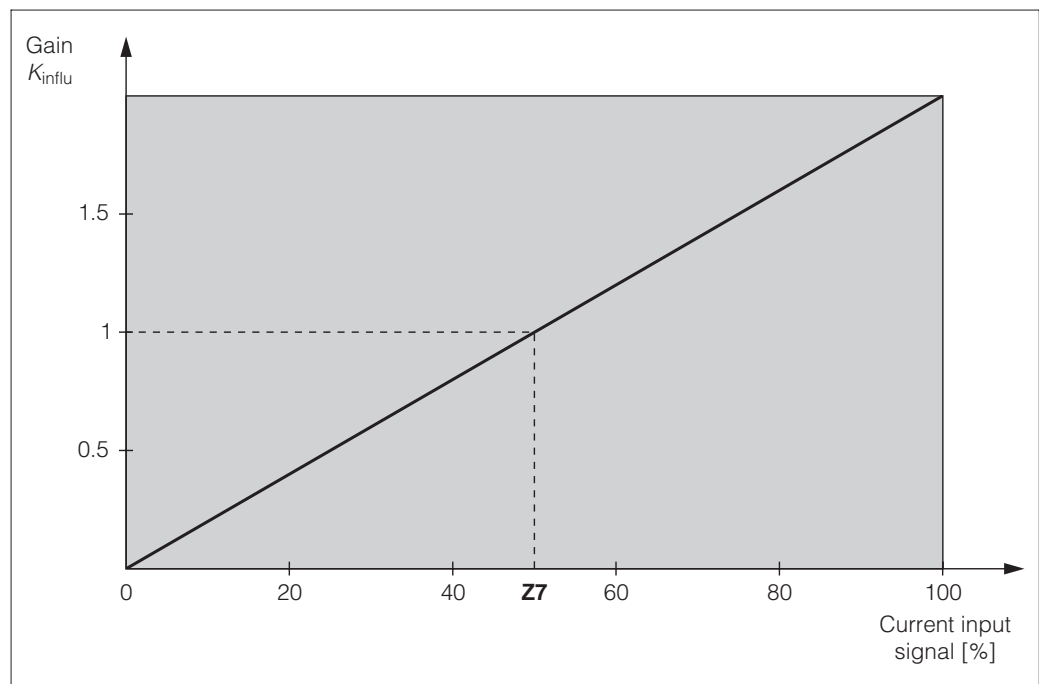

Multiplying feedforward control  
Fig. 5.6

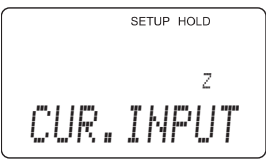
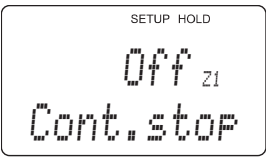
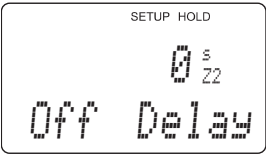
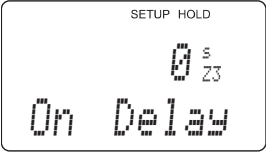
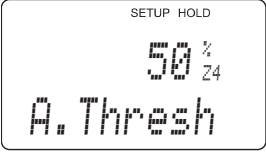
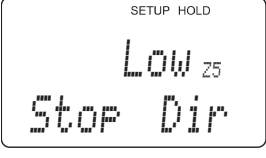
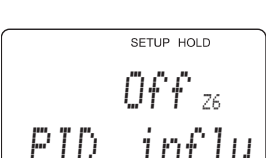
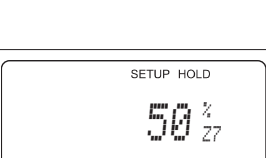
Coding	Field	Selection or range Factory setting (bold)	Display	Info
<b>Z</b>	<b>Function group CURRENT INPUT</b>			Initial display in function group CURRENT INPUT.
Z1	Select flow rate monitoring of main stream (with controller switch-off)	<b>Off</b> Input		Only switch on when flow meter is connected in main stream.  When Z1 = Off, fields Z2 to Z5 do not exist.
Z2	Enter delay for controller switch-off by current input	<b>0 s</b> 0 ... 2000 s		Short-term flow rate undershots can be suppressed by delay and will not cause controller switch-off.
Z3	Enter delay for controller switch-on by current input	<b>0 s</b> 0 ... 2000 s		
Z4	Enter switch-off threshold for current input	<b>50%</b> 0 ... 100%		0 ... 100% corresponds to 4 ... 20 mA at current input. Note the measured value allocation to the current output of the flow meter.
Z5	Select orientation stop for current input	<b>Low</b> High		If the value entered in Z4 is exceeded low or high, the controller switches off.
Z6	Select feedforward control for PID controller	<b>Off</b> lin = linear Basic		When Z6 = Off, Z7 does not exist.  Basic = Feedforward control only affects the basic load (alternatively dosage in proportion to quantity, if common PID control is not possible, e.g. due to sensor defect)
Z7	Enter value for feedforward control at which modulation gain = 1	<b>50%</b> 0 ... 100%		When the value is set, the controller manipulated value with feedforward control on is identical to feedforward control off.

### 5.4 Current outputs

The function group CURRENT OUTPUT is used to configure the individual outputs. Either a linear (O3 (1)) or, in conjunction with the Plus package, a user-defined current output characteristic (O3 (3)) can be entered. Furthermore, a current output value can be simulated to check the current outputs (O3 (2)). The controller set value in field R 237 can be output via current output 2, if available.

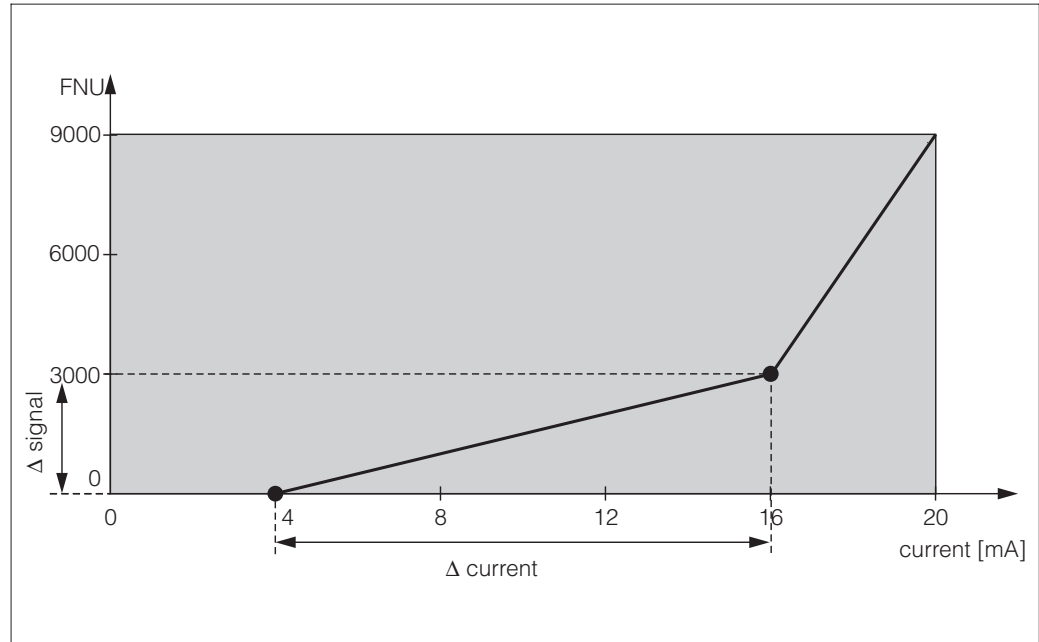

Fig. 5.7 User-defined current output characteristic

The distance  $\Delta$  signal between two table value pairs must exceed:

- 0.005 FNU / NTU / ppm / mg/l / %
- 0.05 g/l
- Temperature: 0.25 °C

First enter the current output configuration you require in the following blank table. Ensure the required minimum distance by calculating the resulting signal distance **per mA**. Then enter the result in the instrument.

Value pair	Current output 1			Current output 2		
	Tu / °C [ ]	Current [mA]	Distance per mA	Tu / °C [ ]	Current [mA]	Distance per mA
1						
2						
3						
4						
5						
6						
7						
8						
9						
10						

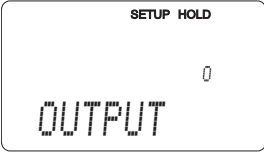
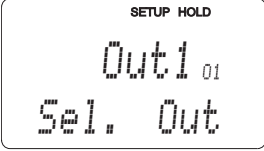
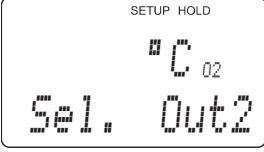
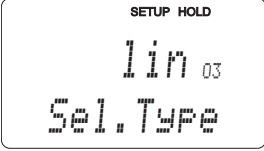
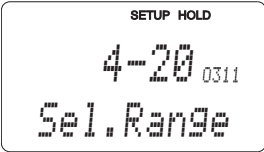
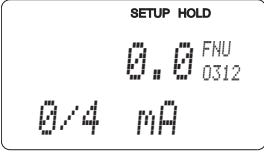
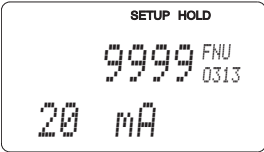
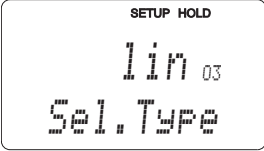
Coding	Field	Selection or range Factory setting (bold)	Display	Info	
O	Function group <b>CURRENT OUTPUT</b>			Initial display in function group CURRENT OUTPUT.	
O1	Select current output	<b>Out1</b> <i>Out2</i>		Select the operating mode / characteristic separately for each output.	
O2	Select measured quantity for 2nd current output	°C mg/l <i>Contr</i>		Selection of Curr (= current output 2) in field R237 is only possible, if field O2 = Contr is selected.	
O3 (1)	Enter or output linear characteristic	<b>lin</b> = linear (1) <i>sim</i> = simulation (2) <i>Tab</i> = Table (3)		The characteristic can have a positive or negative slope at the measured value output.  At set value output (O2 = Contr), the increasing current corresponds to an increasing set value.	
	O311	Selection of current range	<b>4-20 mA</b> <i>0-20 mA</i>		
	O312	0/4 mA value; enter corresponding turbidity or temperature value	<b>0.0 NTU</b> <b>0.0 FNU</b> <b>0.0 ppm</b> <b>0.0 mg/l</b> <b>0.0 g/l</b> <b>0.0 kg/l</b> <b>0.0 t/m3</b> <b>0.0 %</b> <b>0.0 °C</b>		Enter the measured value corresponding to the minimum current value (0/4 mA) at the transmitter output. Display format from A3.
	O313	20 mA value; enter corresponding turbidity or temperature value	<b>10.00 NTU</b> <b>10.00 FNU</b> <b>10.00 ppm</b> <b>10.00 mg/l</b> <b>300.0 g/l / 3.00 g/l</b> <b>99.99 kg/l</b> <b>99.99 t/m3</b> <b>10.0 %</b> <b>100.0 °C</b>		Enter the measured value corresponding to the minimum current value (0/4 mA) at the transmitter output. Display format from A3.  If two factory settings are given, then the left-hand one is valid for CUS 41, the right-hand one for CUS 31.
O3 (2)	Current output is simulated	<i>lin</i> = linear (1) <b>sim</b> = simulation (2) <i>Tab</i> = Table (3)		The simulation is terminated by selecting (1) or (3). See O3 (1), O3 (3) for other characteristics.	

Factory settings are printed in **bold** face;  
base version does not include functions in *italic*.

Coding		Field	Selection or range Factory setting (bold)	Display	Info
	O321	Enter simulation value	<b>Current value</b> 0.00 ... 22.00 mA	<p>SETUP HOLD 4.00<sup>mA</sup><sub>0321</sub> Simulat.</p>	The current value entered here is output through the current output.
O3 (3)		Enter current output table (only with Plus package)	lin = linear (1) sim = simulation (2) <b>Tab = Table (3)</b>	<p>SETUP HOLD table<sub>03</sub> Sel.Type</p>	Values may also be added or changed at a later point in time. The values entered are automatically sorted in ascending order by current value. The display, however, is not in sorted order. See O3 (1), O3 (2) for other characteristics.
	O331	Selection of table option	<b>Read</b> Edit	<p>SETUP HOLD read<sub>0331</sub> Sel.Table</p>	Check (Read) or enter (Edit) a characteristic.
	O332	Enter number of table value pairs	<b>1</b> 1 ... 10	<p>SETUP HOLD 1<sub>0332</sub> No. Elem.</p>	This is where the number of pairs of x and y value (measured value and associated current value) is entered.
	O333	Select table value pair	<b>1</b> 1 ... Number of table value pairs Finished	<p>SETUP HOLD 1<sub>0333</sub> Sel.Elem.</p>	The function chain O333 ... O335 will run though as many times as correspond to the value in O332. "Assign" appears as the last step. After confirmation the system jumps to O336.
	O334	Enter x value (measured value)	<b>0.0 NTU</b> <b>0.0 FNU</b> <b>0.0 ppm</b> <b>0.0 mg/l</b> <b>0.0 g/l</b> <b>0.0 kg/l</b> <b>0.0 t/m3</b> <b>0.0 %</b> <b>0.0 °C</b>	<p>SETUP HOLD 0.0<sup>FNU</sup><sub>0334</sub> Meas.val.</p>	x value = measured value determined by user.
	O335	Enter y value (current value)	<b>4.00 mA</b> 0.00 ... 20.00 mA	<p>SETUP HOLD 0.00<sup>mA</sup><sub>0335</sub> mA value</p>	y value = current value determined by user to be associated with measured value entered in O334.
	O336	Message to say whether table status is OK	<b>yes</b> no	<p>SETUP HOLD yes<sub>0236</sub> Status ok</p>	Return to O3. If status = "no", set table correctly (all previous settings are kept) or back to measurement mode (table will be deleted).

Factory settings are printed in **bold** face; base version does not include functions in *italic*.

## 5.5 Monitoring functions

The monitoring functions are used to define various alarms and to set output contacts. Each individual error can be defined to be effective or not (at the contact or as an error current). An alarm condition can be defined to activate a cleaning function (F8).

### 5.5.1 Alarm

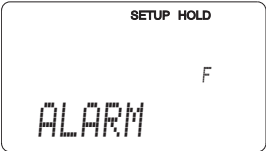
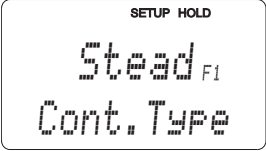
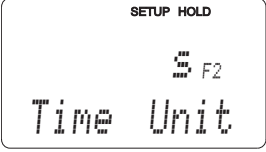
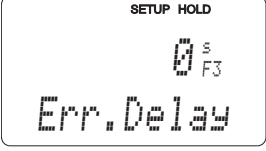
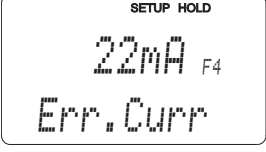
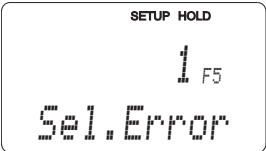
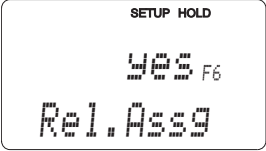
Coding	Field	Selection or range Factory setting (bold)	Display	Info
F	<b>Function group ALARM</b>			Alarm function settings.
F1	Selection of contact type	<b>Stead = steady contact</b> Fleet = fleeting contact		The contact type selected here only applies to the alarm contact.
F2	Selection of time unit	<b>s</b> min		
F3	Enter alarm delay	<b>0 s (min)</b> 0 ... 2000 s (min)		Depending on the unit selected in F2, the alarm delay is entered in s or min.
F4	Selection of error current	<b>22 mA</b> 2.4 mA		This selection must be made even if all errors are suppressed in F5. If you did not select "0–20 mA" in O311, you may not use "2.4 mA".
F5	Selection of error number	<b>1</b> 1 ... 255		All errors can be selected for which an alarm message should occur. Select using the fault numbers. For individual error numbers, please refer to the table in chap. 7. The factory settings remain in effect for all errors not edited.
F6	Make alarm contact effective for selected errors	<b>yes</b> no From E080 factory setting <b>no</b>		If set to "no", all the other alarm settings (e.g. alarm delay) are also deactivated. The settings themselves are retained. This setting <b>only</b> applies to the error selected in F5.

Coding	Field	Selection or range Factory setting (bold)	Display	Info
F7	Set error current to be effective for selected error	<b>no</b> yes	<div style="border: 1px solid black; padding: 5px; text-align: center;">                     SETUP HOLD   <i>no</i> F7   <i>Curr. Assg</i> </div>	The error current selected in F4 becomes effective or is suppressed in case of error. This setting <b>only</b> applies to the faults selected in F5.
F8	Automatic start of cleaning function? (Only with Plus package)	<b>no</b> yes	<div style="border: 1px solid black; padding: 5px; text-align: center;">                     SETUP HOLD   <i>no</i> F8   <i>CleanTrig</i> </div>	This field does not exist for some errors, see chap. 7.
F9	Return to menu or select next error	<b>next = next error</b> <b>←R</b>	<div style="border: 1px solid black; padding: 5px; text-align: center;">                     SETUP HOLD   <i>next</i> F9   <i>Select</i> </div>	If ← is selected, the display returns to F. If next is selected, the display returns to F5.

Factory settings are printed in **bold** face; base version does not include functions in *italic*.

5.5.2 Check

The function group CHECK is only accessible for instruments equipped with the Plus packet.

PCS alarm (Process Check System)

This function is used to examine the measuring signal for deviations. If the measuring signal is constant for a specific period of time (several measured values), an alarm is issued. This type of sensor behaviour may be caused by soiling or similar.



**Note:**

A current PCS alarm is automatically deleted as soon as the sensor signal changes.

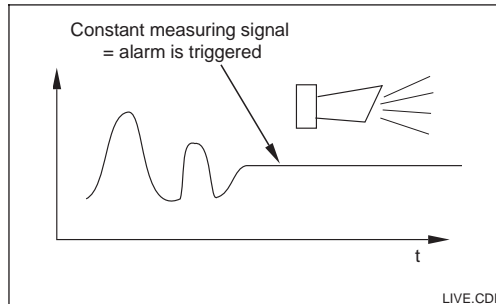

Fig. 5.8 PCS alarm (live-check)

Coding	Field	Selection or range Factory setting (bold)	Display	Info
<i>P</i>	<b>Function group CHECK</b>			Settings for sensor and process monitoring
P1	Select process monitoring	<b>Off</b> Low High Lo+Hi = low + high Lo! Hi! LoHi!		Alarm signalling optionally with or without simultaneous controller switch-off. xxxx = without controller switch-off xxxx! = with controller switch-off
P2	Enter error delay	<b>0 s (min)</b> 0 ... 2000 s (min)		Depending on your selection in F2, you can enter the error delay in min or s. Only after this does a high or low limit violation cause an alarm as per field P4 / P5.
P3	Enter lower alarm threshold	<b>0.000 NTU</b> 0 ... 9999 NTU		
P4	Enter upper alarm threshold	<b>9999 NTU</b> 0 ... 9999 NTU		

Factory settings are printed in **bold** face; base version does not include functions in *italic*.

Coding	Field	Selection or range Factory setting (bold)	Display	Info
P5	Select process monitoring (PCS alarm)	<b>Off</b> AC CC AC+CC AC! CC! ACCC!		AC = Sensor alternation check CC = Controller check  Alarm signalling optionally with or without simultaneous controller switch-off. xxxx = without controller switch-off xxxx! = with controller switch-off
P6	Enter maximum permissible period for lower alarm threshold	<b>60 min</b> 0 ... 2000 min		Only if P5 = CC or AC+CC.
P7	Enter maximum permissible period for upper alarm threshold	<b>120 min</b> 0 ... 2000 min		Only if P5 = CC or AC+CC.
P8	Enter alarm threshold (for P6 / P7)	<b>0.000 NTU</b> 0 ... 9999 NTU		Selected value is an absolute value. This function is mainly used for batch process and single-sided limit switches.

Factory settings are printed in **bold** face;  
base version does not include functions in *italic*.

## 6.1 Relay contact configuration

The function group RELAYS is only accessible for instruments equipped with the Plus packet.

The relay contacts described below can be selected and configured as required (max. four contacts depending on options installed):

- Limit contactor for measured turbidity value R2 (1)
- Limit contactor for temperature: R2 (2)
- P(ID) controller: R2 (3)
- Timer for cleaning function: R2 (4)
- ChemoClean function R2 (5)

### 6.1.1 Limit contactor for measured turbidity value and temperature

The relay contacts in the transmitter can be assigned different functions. Switch-on and switch-off points and pickup and dropout delays can be defined for the limit contactor. Moreover, an alarm threshold can be set to issue an error message and to start a cleaning function. These functions may be used for turbidity and temperature measurement.

Please refer to Fig. 5.5 for a graphic representation of the alarm contact states of any relay or alarm contact.

When the measured value increases (max. function), the relay contact is closed at time  $t_2$  when the switch-on point has been exceeded ( $t_1$ ) and the pickup delay ( $t_2 - t_1$ ) has expired. When the alarm threshold ( $t_3$ ) is reached and the alarm delay ( $t_4 - t_3$ ) also has expired, the alarm contact is switched. When the measured value decreases, the alarm contact is reset when the measured value drops below the alarm threshold ( $t_5$ ). The relay contact is also reset ( $t_7$ , after the dropout delay  $t_7 - t_6$ ). When the pickup and dropout delays are set to 0 s, the switch-on and switch-off points are identical to the contact switching points. Settings analogous to the max function can also be made for a min function.

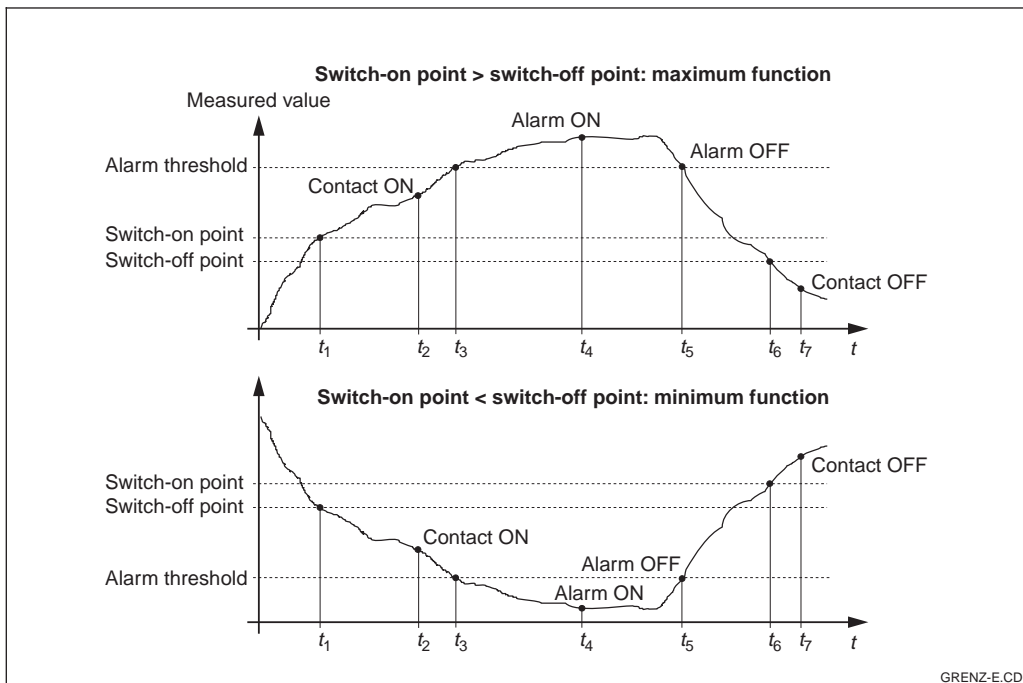

Fig. 6.1 Depiction of alarm functions

### 6.1.2 P(ID) controller

The transmitter supports the definition of various controller functions. On the basis of the PID controller, P, PI, PD and PID controllers can be implemented. To obtain the best control response, use the controller best suited to the application in question.

- **P controller:** Used for simple linear control purposes with small system deviations. Where major changes are to be controlled, overshooting may occur. A control offset is to be expected.
- **PI controller:** Used for processes where overshooting is to be avoided and permanent offsets are not allowed.
- **PD controller:** Used for processes that require quick response and where peaks are to be corrected.
- **PID controller:** Used for processes for which the type of control provided by a P, PI or PD controller is inadequate.

#### Adjustments of P(ID) controller

Three parameters can be adjusted in the case of a PID controller:

- the control gain  $K_p$  (P influence)
- the integral action time  $T_n$  (I influence)
- the derivative action time  $T_v$  (D influence)

#### Start-up

If there are no empirical values available for setting the control parameters, use values that provide the greatest possible stability of the control loop. To optimise the control loop further:

- Increase the control gain  $K_p$  until the control variable just starts to overswing.
- Decrease  $K_p$  again slightly and shorten the integral action time  $T_n$  to achieve the shortest possible correction time without overswing.
- In order to shorten the response time of the controller, you also have to set the derivative action time  $T_v$ .

Checking and fine tuning of parameter settings using a recorder

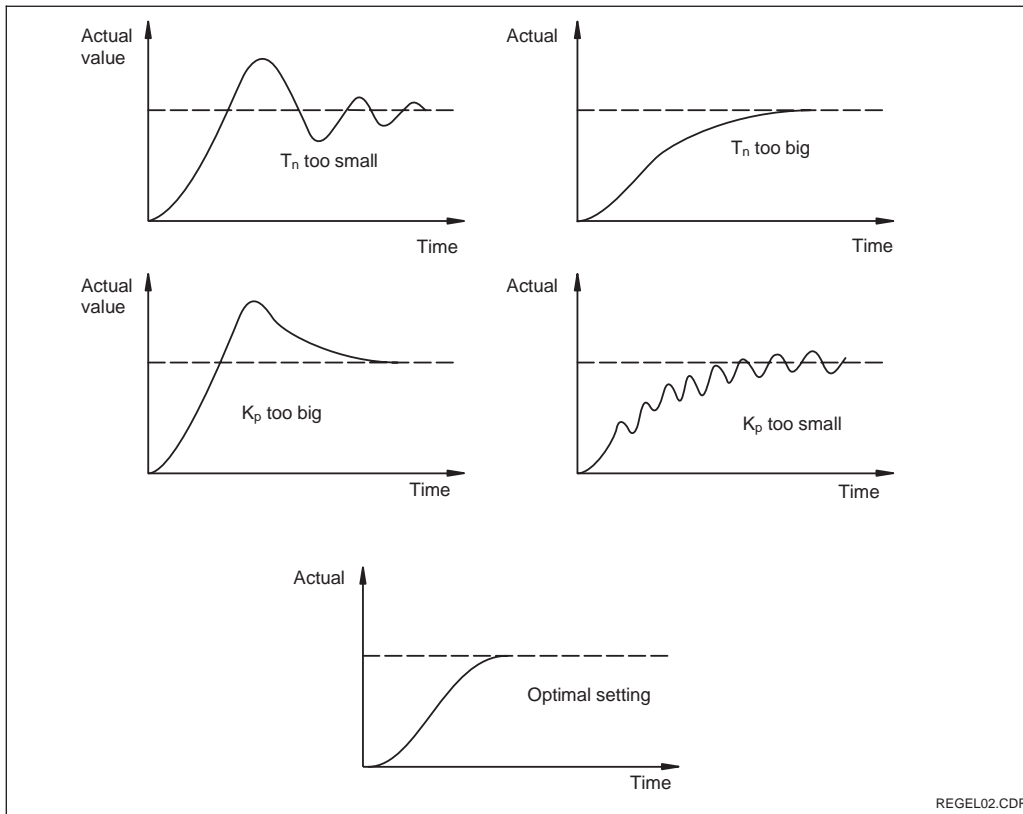

Fig. 6.2 Setting optimisation T<sub>n</sub> and K<sub>p</sub>

Actuating signal outputs (R237 ... R2310)

The control contact in question outputs a switched signal. The intensity of this signal is proportional to the controller's output. A distinction is made according to the type of signal clock:

- Pulse length modulation**  
 The greater the calculated control output, the longer the contact in question remains picked up. The period can be adjusted between 0.5 and 99 s. Pulse-length modulated outputs are used to control solenoid valves.
- Pulse frequency modulation**  
 The greater the calculated control output, the higher the switching frequency of the contact. The maximum switching frequency  $1/T$  can be adjusted between 60 and 180 min<sup>-1</sup>. The ON period  $t_{ON}$  is constant. Pulse frequency-modulated outputs are intended for controlling solenoid-operated metering pump s.

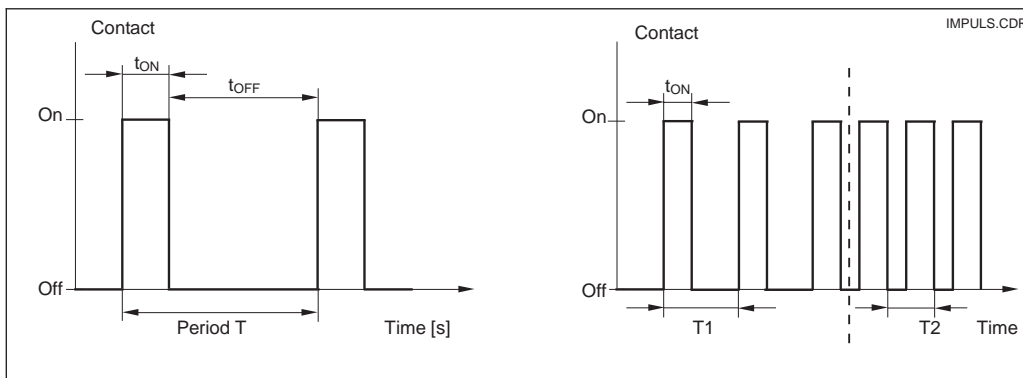

Fig. 6.3 Signal of a pulse length-modulated (left) and a pulse frequency-modulated control contact (right)

**Control characteristic for direct and inverse control action**

Field R236 offers two control characteristics for selection which have the effects shown in the following diagram.

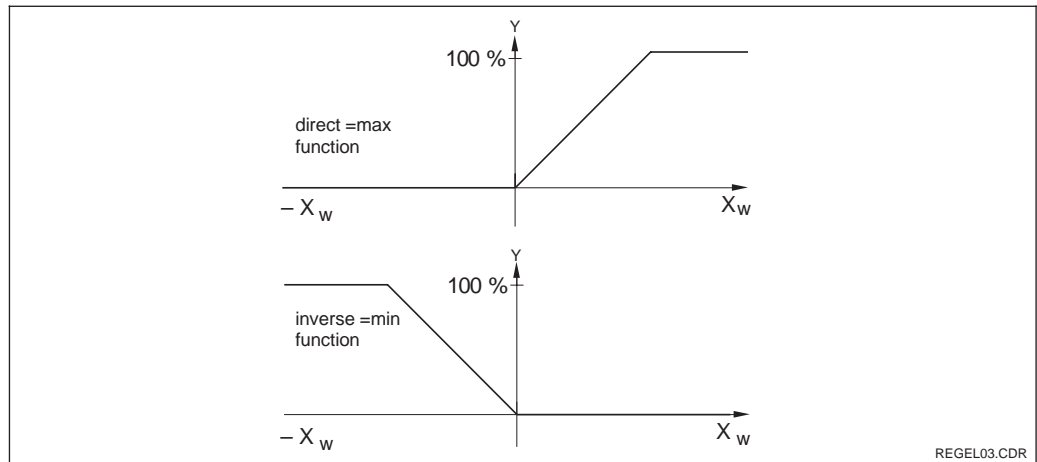

Fig. 6.4 Control characteristic of a proportional-action controller with direct and inverse control action

**6.1.3 Timer for cleaning function**

This function can be used to implement a simple cleaning routine. The user can specify a time interval after which cleaning is to start; i.e. only constant intervals can be defined.



**Note:**

The timer and ChemoClean do not work independently of each other. Whilst one of the functions is active, the other cannot be started.

There are other cleaning functions in conjunction with the ChemoClean function (version with four contacts, see chap. 5.5.4).

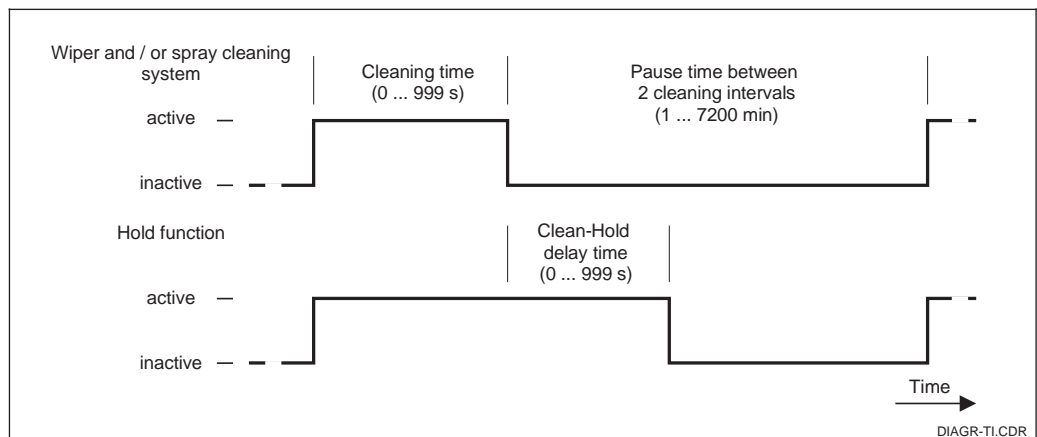

Fig. 6.5 Relationship between cleaning time, pause time and hold delay time

### 6.1.4 ChemoClean function

Just like the timer function, ChemoClean can also be used to start a cleaning cycle. However, ChemoClean supports different cleaning and rinse intervals.

Thus, irregular cleaning with different repeat cycles is possible, and cleaning times with post-rinse times can be individually defined.



**Note:**

- The ChemoClean function is only available with relays 3 (water) and 4 (cleaner).
- Abortion of the cleaning process is always followed by a post-rinse time.
- When "Economy" is selected, cleaning is performed with water only.

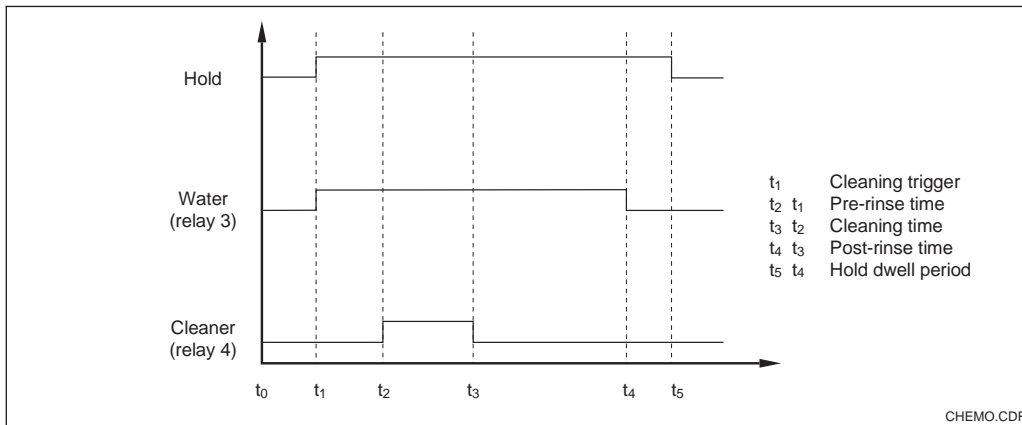

Fig. 6.6 Sequence of a cleaning cycle

Coding	Field	Selection or range Factory setting (bold)	Display	Info
R	Function group <b>RELAY</b>			Relay contacts can be selected and adjusted.
R1	Selection of contact to be configured	<b>Rel1</b> <i>Rel2</i> <i>Rel3</i> <i>Rel4</i>		Rel3 (water) and Rel4 (cleaner) are only available on transmitter equipped accordingly. If ChemoClean is selected as the cleaning type, Rel4 is not available.
R2 (1)	Configuration limit contactor for turbidity measurement	<b>LC PV = Limit contactor TU (1)</b> LC °C = Limit contactor T (2) PID controller (3) Timer (4) <i>Clean = ChemoClean (5)</i>		PV = Process value  If Rel4 is selected in Field R1, Clean = ChemoClean cannot be selected. Confirmation with ENTER switches off a different, already switched-on function and its settings are reset to the default.



Factory settings are printed in **bold** face; base version does not include functions in *italic*.

Coding	Field	Selection or range Factory setting (bold)	Display	Info
R211	Switch function of R2 (1) off or on	<b>off</b> on		All settings are retained.
R212	Enter switch-on point of contact.	<b>9999 NTU</b> <b>9999 FNU</b> <b>9999 ppm / 3000 ppm</b> <b>9999 mg/l / 3000 mg/l</b> <b>300.0 g/l / 3 g/l</b> <b>99.99 kg/l</b> <b>99.99 t/m3</b> <b>200.0 %</b>		Never set the switch-on point and switch-off point to the same value. (Comp. chap. 5.1.1.) (Only the operating mode selected in A1 appears.) If two factory settings are given, then the left-hand one is valid for CUS 41, the right-hand one for CUS 31.
R213	Enter switch-off point of contact	<b>9999 NTU</b> <b>9999 FNU</b> <b>9999 ppm / 3000 ppm</b> <b>9999 mg/l / 3000 mg/l</b> <b>300.0 g/l / 3 g/l</b> <b>99.99 kg/l</b> <b>99.99 t/m3</b> <b>200.0 %</b>		Entering the switch-off point selects either a max contact (switch-off point < switch-on point) or a min contact (switch-off point > switch-on point) and implements a constantly required hysteresis (see Fig. 5.5). If two factory settings are given, then the left-hand one is valid for CUS 41, the right-hand one for CUS 31.
R214	Enter pickup delay	<b>0 s</b> 0 ... 2000 s		
R215	Enter dropout delay	<b>0 s</b> 0 ... 2000 s		
R216	Enter alarm threshold (as an absolute value)	<b>9999 NTU</b> <b>9999 FNU</b> <b>9999 ppm / 3000 ppm</b> <b>9999 mg/l / 3000 mg/l</b> <b>300.0 g/l / 3 g/l</b> <b>99.99 kg/l</b> <b>99.99 t/m3</b> <b>200.0 %</b>		When the alarm threshold is exceeded/undershot, the measuring transmitter issues an alarm with an error message and error current (note alarm delay).  When defining the min contact, the alarm threshold must be set to a lower value than the switch-off point.  If two factory settings are given, then the left-hand one is valid for CUS 41, the right-hand one for CUS 31.

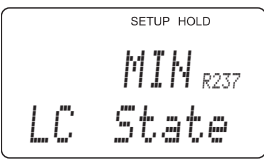
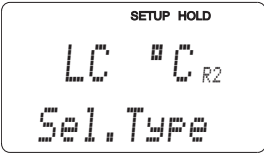
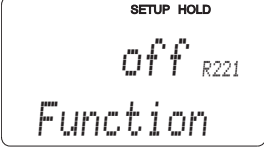
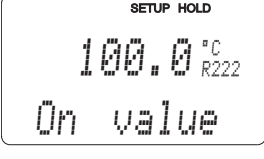
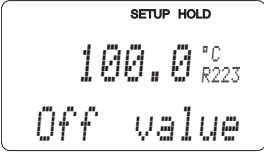
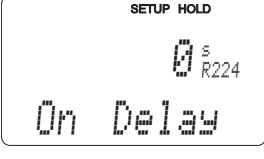
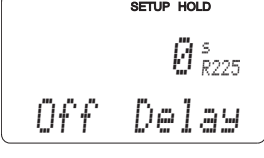
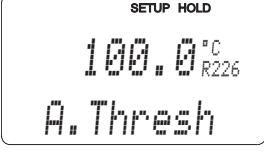
The factory settings are printed in **bold** face; base version does not include functions in *italic*.

Coding		Field	Selection or range Factory setting (bold)	Display	Info
	R217	Show status for limit contact	<b>MAX</b> MIN		Only display.
	R2 (2)	Configure limit contactor for temperature measurement	LC PV = Limit contactor TU (1) <b>LC °C = Limit contactor T</b> (2) PID = PID controller (3) Timer (4) <i>Clean = ChemoClean</i> (5)		Confirmation with ENTER switches off a different, already switched-on function and its settings are reset to the default.
	R221	Switch function of R2 (2) off or on	<b>off</b> on		
	R222	Enter switch-on temperature	<b>100.0 C</b> 5.0 ... 100.0 C		Never set switch-on point and switch-off point to the same value! (see chap. 5.1.1.)
	R223	Enter switch-off temperature	<b>100.0 C</b> 5.0 ... 100.0 C		Entering the switch-off point selects either a max contact (switch-off point < switch-on point) or a min contact (switch-off point > switch-on point) and a constantly required hysteresis is implemented (see 6.)
	R224	Enter pickup delay	<b>0 s</b> 0 ... 2000 s		
	R225	Enter dropout delay	<b>0 s</b> 0 ... 2000 s		
	R226	Enter alarm threshold (as an absolute value)	<b>150.0 °C</b> -20.0 ... 150.0 °C		When the alarm threshold is exceeded/undershot, the transmitter issues an alarm with an error message and error current (note alarm delay). When defining the min contact, the alarm threshold must be set to a lower value than the switch-off point.

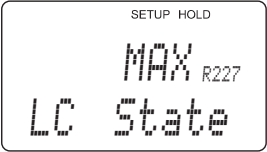
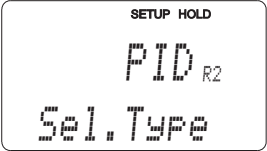
Factory settings are printed in **bold** face;  
base version does not include functions in *italic*.

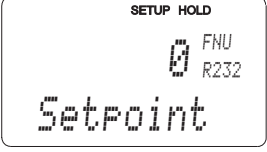
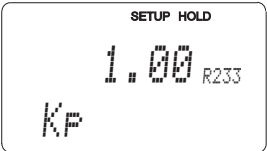
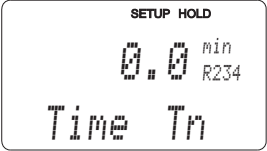
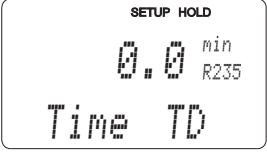
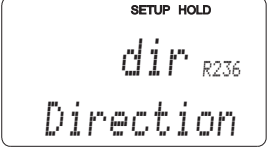
Coding		Field	Selection or range Factory setting (bold)	Display	Info
	R227	Show status for limit contact	<b>MAX</b> MIN		Only display.
	R2 (3)	P(ID) controller configuration	LC PV = Limit contactor TU (1) LC °C = Limit contactor T (2) <b>PID controller</b> (3) Timer (4) <i>Clean = ChemoClean</i> (5)		Confirmation with ENTER switches off a different, already switched-on function and its settings are reset to the default.
	R231	Switch function of R2 (3) off or on	<b>Off</b> On Basic PID+B		On = PID control Basic = only basic load dosage PID+B = PID control with basic load dosage
	R232	Enter set point	<b>0 NTU</b> <b>0 FNU</b> <b>0 ppm</b> <b>0 mg/l</b> <b>0.0 g/l</b> <b>0.0 kg/l</b> <b>0.0 t/m3</b> <b>0.0 %</b>		The set point is the value to be maintained by the control. This value is to be re-establish by the control in the event of any deviation (up or down).
	R233	Enter control gain $K_p$	<b>1.00</b> 0.01 ... 20.00		See chap. 5.1.2, p. 38.
	R234	Enter integral action time $T_n$ (0.0 = no I component)	<b>0.0 min</b> 0.0 ... 999.9 min		See chap. 5.1.2. Each hold resets the I component to zero. Hold can be deactivated in S2, but not for ChemoClean and timer or wiper!
	R235	Enter derivative action time $T_v$ (0.0 = no D component)	<b>0.0 min</b> 0.0 ... 999.9 min		See chap. 5.1.2.
	R236	Selection of controller characteristic	<b>dir</b> = direct inv = inverted		Setting may or may not be required depending on control deviation (up or down deviation, see chap. 5.1.2).

The factory settingFactory settings are printed in **bold** face;  
base version does not include functions in *italic*.

Coding		Field	Selection or range Factory setting (bold)	Display	Info
	R237	Selection of pulse length or pulse frequency	<b>len</b> = Pulse length freq = Pulse frequency curr = Current output2	<div style="border: 1px solid black; padding: 5px; text-align: center;"> <small>SETUP HOLD</small>  <b>len</b> <small>R237</small>                      Oper. Mode                 </div>	Pulse length e.g. for solenoid valve, pulse frequency e.g. for solenoid-operated metering pump (see chap. 5.5.2). Selection of current output 2 is only possible, if field O2 = Contr is selected.
	R238	Enter pulse interval	<b>10.0 s</b> 0.5 ... 999.9 s	<div style="border: 1px solid black; padding: 5px; text-align: center;"> <small>SETUP HOLD</small>  <b>10.0</b> <sup>s</sup> <small>R238</small>                      PulsePer.                 </div>	This field only appears if pulse length is selected in R237. When pulse frequency is selected, R238 is skipped and input continues in R239.
	R239	Enter maximum pulse frequency of actuator	<b>120 min<sup>-1</sup></b> 60 ... 180 min <sup>-1</sup>	<div style="border: 1px solid black; padding: 5px; text-align: center;"> <small>SETUP HOLD</small>  <b>120</b> <sup>1/min</sup> <small>R239</small>                      Max.PFreq                 </div>	This field only appears if pulse frequency is selected in R237. When pulse length is selected, R239 is skipped, and input continues in R2310.
	R2310	Minimum ON time $t_{ON}$	<b>0.3 s</b> 0.1 ... 5.0 s	<div style="border: 1px solid black; padding: 5px; text-align: center;"> <small>SETUP HOLD</small>  <b>0.3</b> <sup>s</sup> <small>R2310</small>                      Min.PTime                 </div>	This field only appears if pulse length is selected in R237.
	R2311	Enter basic load	<b>0%</b> 0 ... 40%	<div style="border: 1px solid black; padding: 5px; text-align: center;"> <small>SETUP HOLD</small>  <b>0</b> % <small>R2411</small>                      BasicLoad                 </div>	Selecting the basic load, you choose the desired dosage quantity. 100% basic load corresponds to: steadily on at R237 = on $F_{max}$ at R237 = freq 20 mA at R237 = curr
R2 (4)		Configure cleaning function (Timer)	LC PV = Limit contactor TU (1) LC °C = Limit contactor T (2) PID controller (3) <b>Timer</b> (4) <i>Clean = ChemoClean (5)</i>	<div style="border: 1px solid black; padding: 5px; text-align: center;"> <small>SETUP HOLD</small>  <b>Timer</b> <small>R2</small>                      Sel.Type                 </div>	Cleaning with only <i>one</i> cleaning agent (usually water) and poss. as Wipe-Wash function together with the wiper (see Fig. 5.5 and setting in B1). Confirmation with ENTER switches off a different, already switched-on function and its settings are reset to the default.
	R241	Switch function of R2 (4) off or on	<b>off</b> on	<div style="border: 1px solid black; padding: 5px; text-align: center;"> <small>SETUP HOLD</small>  <b>off</b> <small>R241</small>                      Function                 </div>	
	R242	Enter rinse / cleaning time	<b>30 s</b> 0 ... 999 s	<div style="border: 1px solid black; padding: 5px; text-align: center;"> <small>SETUP HOLD</small>  <b>30</b> <sup>s</sup> <small>R242</small>                      RinseTime                 </div>	The hold and relay settings are activated for the period of time specified here.

Factory settings are printed in **bold** face;  
base version does not include functions in *italic*.

Coding		Field	Selection or range Factory setting (bold)	Display	Info
	R243	Enter pause time	<b>360 min</b> 1 ... 7200 min	SETUP HOLD 360 <sup>min</sup> <sub>R343</sub> PauseTime	The pause time is the time between two cleaning cycles (see chap. 5.5.4).
	R244	Enter minimum pause time	<b>120 min</b> 1 ... 3600 min	SETUP HOLD 120 <sup>min</sup> <sub>R244</sub> Min.Pause	The minimum pause time prevents continuous cleaning when the cleaning trigger is present.
R2 (5)		Configure ChemoClean function (on version with four contacts and appropriate assignment of contacts 3 and 4)	LC PV = Limit contactor cond. (1) LC °C = Limit contactor T (2) PID = PID controller (3) Timer (4) <b>Clean = ChemoClean (5)</b>	SETUP HOLD Clean <sub>R2</sub> Sel.Type	See chap. 5.5.4.  Contact 3 = Water, Contact 4 = Cleaner. Confirmation with ENTER switches off a different, already switched-on function and its settings are reset to the default.
	R251	Switch function of R2 (5) off or on	<b>off</b> on	SETUP HOLD off <sub>R251</sub> Function	
	R252	Selection of start pulse	<b>int = internal (timer-contr.)</b> ext = external (digital input 2) i+ext = intern. + extern. i+stp = internal, suppressed by external	SETUP HOLD int <sub>R252</sub> CleanTrig	The "int" cycle is triggered by the end of the pause time (R257). There is no real-time clock. External suppression is required for irregular time intervals (e.g. at weekends)
	R253	Enter pre-rinse time	<b>20 s</b> 0 ... 999 s	SETUP HOLD 20 <sup>s</sup> <sub>R253</sub> PreRinse	Water is used for rinsing.
	R254	Enter cleaning time	<b>10 s</b> 0 ... 999 s	SETUP HOLD 10 <sup>s</sup> <sub>R254</sub> CleanTime	Cleaning agent and water are used for cleaning.
	R255	Enter post-rinse time	<b>20 s</b> 0 ... 999 s	SETUP HOLD 20 <sup>s</sup> <sub>R255</sub> PostRinse	Water is used for rinsing.

The factory settings are functions in *italic* face; base version does not include functions in *italic*.

Coding		Field	Selection or range Factory setting (bold)	Display	Info
	R256	Enter number of repeat cycles	<b>0</b> 0 ... 5	<div style="border: 1px solid black; padding: 5px; text-align: center;">                     SETUP HOLD                      0 <small>R256</small>  <i>Ref. Rate</i> </div>	R253 ... R255 is repeated.
	R257	Enter pause time	<b>360 min</b> 1 ... 7200 min	<div style="border: 1px solid black; padding: 5px; text-align: center;">                     SETUP HOLD                      360 <small>min</small> <small>R257</small>  <i>PauseTime</i> </div>	The pause time is the time between two cleaning cycles.
	R258	Enter minimum pause time	<b>120 min</b> 1 ... R 257	<div style="border: 1px solid black; padding: 5px; text-align: center;">                     SETUP HOLD                      120 <small>min</small> <small>R258</small>  <i>Min. Pause</i> </div>	The minimum pause time prevents continuous cleaning when the external cleaning trigger is present.
	R259	Enter number of cleaning cycles without cleaning agent (economy function)	<b>0</b> 0 ... 9	<div style="border: 1px solid black; padding: 5px; text-align: center;">                     SETUP HOLD                      0 <small>R259</small>  <i>EconomyCl</i> </div>	Cleaning with cleaner can be followed by up to 9 cleaning cycles that use only water until the next cleanig cycle with cleaner is performed.

The factory settings are functions in *italic*. face; base version does not include functions in *italic*.

### 5.6 Concentration measurement

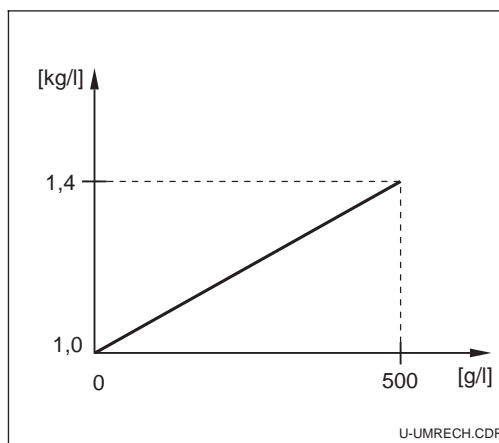

Fig. 5.7 Assignment of measured value to a converted value

The transmitter can convert turbidity values to concentration values as standard. Since not all possible units or the corresponding conversions can be made available, the user can create a custom conversion table.

Any assignment of a measured value to a converted value is possible (see Fig. 5.7). The defined values are connected by a curve based on linear interpolation, i.e. the distances between the points should not be too large.



**Note:**

The conversion is exclusively related to the calibration operating mode %.

Coding	Field	Selection or range Factory setting (bold)	Display	Info
K	<b>Function group CONCENTRATION</b>			Four different concentration curves can be entered into this function group.
K1	Selection of concentration curve, which will be the basis of the display value calculation	<b>1</b> 1 ... 4		The curves are independent of each other. Therefore, you can define four different curves.
K2	Selection of table, you want to edit	<b>1</b> 1 ... 4		The value pairs entered is independent of the curve used (K1). Only when entry is complete is the saved curve overwritten.
K3	Selection of table option	<b>Read</b> Edit		This selection is valid for the concentration curve selected in K2.
K4	Enter number of triplets	<b>1</b> 1 ... 10		Each triplet consists of a numeric pair.



Factory settings are printed in **bold** face; base version does not include functions in *italic*.

Coding	Field	Selection or range Factory setting (bold)	Display	Info
K5	Selection of triplet	<b>1</b> 1 ... Number of support points from K4 Fin		Any triplet can be edited.
K6	Enter turbidity value	<b>0.0 %</b> Entire measuring range		The function chain K5 ... K7 is run through as many times as is equal to the value in K4. "Finished" appears as the last step. After confirmation the system jumps to K8.
K7	Enter concentration value	Entire measuring range		Measurement unit as in A2.
K9	Enter whether or not table status is okay	<b>yes</b> no		Return to K.  If not, then set table correctly (all previous settings are kept) or back to measurement mode (this makes the table invalid).

## 5.7 Service

Coding	Field	Selection or range Factory setting (bold)	Display	Info
<b>S</b>	<b>Function group SERVICE 1</b>			
S1	Selection of language	<b>ENG = English</b> GER = Deutsch FRA = Francais ITA = Italiano NEL = Nederlands ESP = Espanol		This field must be set once during device configuration. After confirmation with ENTER
S2	Hold configuration	<b>S+C = during setup and calibration</b> CAL = during calibration Setup = during setup none = no hold		S = setup, C = calibration.

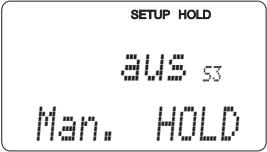
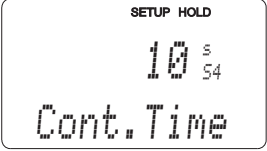
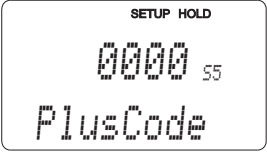
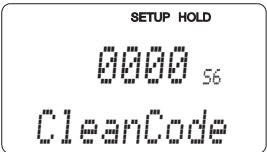
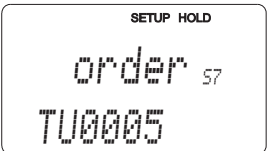
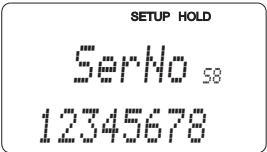
Factory settings are printed in **bold** face;  
base version does not include functions in *italic*.

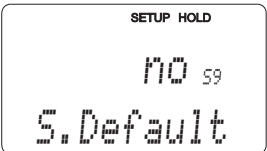
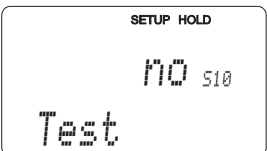
Coding	Field	Selection or range Factory setting (bold)	Display	Info
S3	Manual hold	<b>off</b> on		The setting remains active even after a power failure.
S4	Enter hold dwell period	<b>10 s</b> 0 ... 999 s		
S5	Enter SW upgrade release code (Plus package)	<b>0000</b> 0000 ... 9999		The code is located on the nameplate (see Figs. 1.1 1 and 1.2). Entry of an incorrect code returns you to the measurement menu. The number is edited with the PLUS or MINUS key and confirmed with the ENTER key. "1" is displayed if the code is active.
S6	Enter SW upgrade release code ChemoClean	<b>0000</b> 0000 ... 9999		The code is located on the nameplate (see Figs. 1.1 1 and 1.2). Entry of an incorrect code returns you to the measurement menu. The number is edited with the PLUS or MINUS key and confirmed with the ENTER key. "1" is displayed if the code is inactive.
S7	Order number is displayed			When you upgrade the device
S8	Serial number is displayed			
S9	Reset of instrument (reset to default values) 	<b>no</b> Facy= Factory settings		Facy= All data except language (field S1) are erased and reset to the factory setting!
S10	Perform instrument test	<b>no</b> displ = display test		



Factory settings are printed in **bold** face;  
base version does not include functions in *italic*.

5.8 Service 2

Coding	Field	Selection or range Factory setting (bold)	Display	Info
E	Function group <b>SERVICE 2</b>			
E1	Selection of module	<b>Contr</b> = controller (1) Trans = transmitter (2) Main = power unit (3) Rel = relay (4)		
E111 E121 E131 E141	Software version is displayed			This field cannot be edited. If E1 = Contr: Instrument software If E1 = Trans, Main, Rel: Module firmware
E112 E122 E132 E142	Hardware version is displayed			This field cannot be edited.
E113 E123 E133 E143	Serial number is displayed			This field cannot be edited.
E114 E124 E134 E144	Module name is displayed			This field cannot be edited.

Factory settings are printed in **bold** face;  
base version does not include functions in *italic*.

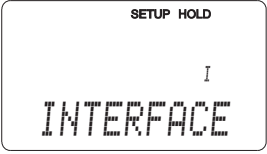
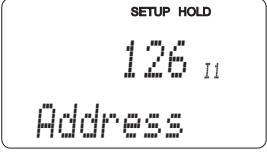
### 5.9 Interfaces

Coding	Field	Selection or range Factory setting (bold)	Display	Info
I	Function group <b>INTERFACE</b>			Only for instruments equipped with communication interface.
I1	Enter address	Address HART: <b>0</b> ... 15 or PROFIBUS: 1 ... <b>126</b>		
I2	Tag description			

The factory settings are printed in **bold**; functions printed in *italics* are not available in the basic version.

### 5.10 Calibration

This function group is used to calibrate the transmitter.

#### Calibration options

- Three-point calibration
- Correction of an existing calibration with the laboratory value
- Modification of individual values of the three-point calibration
- Installation adjustment
- One-point calibration



**Note:**

- If the calibration procedure is aborted by pressing the PLUS and MINUS keys at the same time (return to C115, C123, C135, C143 or C153) or if the calibration is faulty, then the previous calibration data are reinstated. A calibration error is indicated by the "ERR" message and flashing of the electrode symbol on the display. Repeat calibration!
- After calibration, the system returns to Measuring mode. During the hold delay time (Field S4), the Hold symbol appears in the display.

#### Overview of calibration

The calibration of the measuring chain is three-point calibration, i.e., a turbidity ascertained from three samples or from a known solids content of the medium is used to calculate the complete calibration characteristic of the measuring chain for the medium of the transmitter OUM 223 / 253.

It is wise to undertake calibration in the turbidity or solids concentration range in which you want to make measurements.

To simplify the three-point calibration, we suggest to produce three samples required for calibration by thinning a medium sample. Usually, very good calibration results are achieved with the concentration graduations 10 %, 33 % and 100 % of the original concentration. The transmitter suggests this

concentration graduation for the three-point calibration. This method also has the advantage the only the turbidity or solids concentration value of the original laboratory sample need be defined exactly.



**Note:**

In particular, the concentration graduation must be changed for samples with a very high concentration or a very dark colour. Very good results are achieved with a graduation of 3%, 10% and 100%. The original sample must also be measured in the laboratory for results correction after the laboratory measurement.

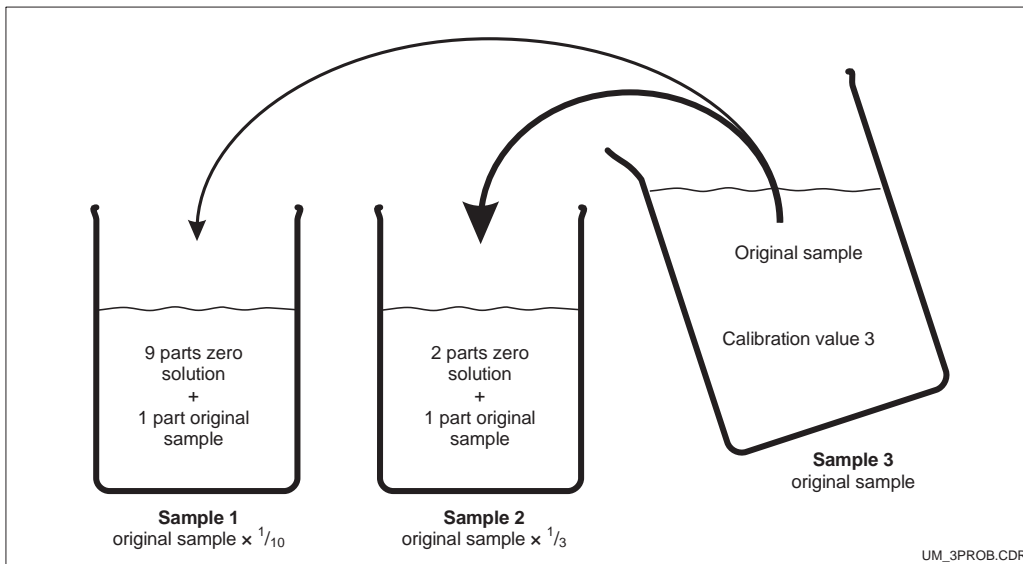

Fig. 5.8 Creation of samples for a three-point calibration

However, this procedure is not a mandatory prerequisite for calibration. You can also take three different samples of the process medium and determine their turbidity or solids concentration values. The following conditions must be met:

- Calibration must be carried out relating to the concentration in increasing order.
- The three samples must differ by at least 10 % relating to the measured value.
- At higher solids concentrations, clean water is sufficient as a zero solution.



**Note:**

- Sludge samples tend to sediment. It is therefore important to stir the sample well, possible even during calibration. When stirring, avoid forming a cyclone by not stirring in a circle.
- The characteristic calculated during the three-point calibration is stored in the currently selected calibration data record (see Field B4). If you select the unchangeable (read only) calibration data record no. 1, no calibration is possible.
- If the calculated relative calibration results deviate by more than -50 % / +100 % from the reference value 100 %, a warning is output (E084). The calibration can be transferred nonetheless.
- If the calculated results lie outside the permitted limits, then the calibration error is displayed (E045). The calibration is not transferred.
- The gas bubble barrier in field B9 has to be 3.0 during calibration.

**Management of the transmitter calibration data records**

There are three calibration data records available for each application (FNU, NTU, ppm, g/l, %). Of these three data records (sample characteristics), one has been permanently programmed at the factory (read only). The other two are stored at the factory as standard characteristics. You can change and adapt these (three-point calibration, one-point adjustment, installation calibration).

	<b>FNU NTU</b>	<b>ppm or mg/l</b>	<b>g/l</b>	<b>%</b>
Data set no. 1	Formazine <b>(read only)</b>	SiO <sub>2</sub> <b>(read only)</b>	Activated sludge <b>(read only)</b>	Residual concrete water <b>(read only)</b>
Data set no. 2	Formazine (Changeable)	Kaolin (Changeable)	Activated sludge (Changeable)	Residual concrete water (Changeable)
Data set no. 3	Formazine (Changeable)	SiO <sub>2</sub> (Changeable)	Activated sludge (Changeable)	Residual concrete water (Changeable)



The data records are saved in the sensor. If you replace the transmitter, this data is not lost. It is loaded automatically (according to the selection) into the transmitter.

**Version TB: Initial settings for residual concrete water**

The version OUM 223-TB and OUM 253-TB contains the Plus package with additional setting options, as for the TS version. On delivery, different values from the standard version are set in the individual fields of the menus to make commissioning as simple as possible.

These initial settings are so selected so that no additional settings need be made for applications in **residual concrete water**. However, should you reset the device to the original factory settings (set default), then you can find the values which are valid for this application.

**Note:**

Should you wish to use a voltage output instead of the current output intended by the factory, then please connected the supplied shunt resistor according to the instructions on the sheet enclosed with the transmitter. You will then obtain a 0 ... 10 V current output.

*Factory settings*

	Menu field	Setting
Mode of operation	A1	spec.
Engineering unit	A2	kg/l
Display format	A3	XX.xx
Measured value damping	A5	10
Calibration data record	B4	3
Current output	O1	Out1
Characteristic	O2	lin
Current range	O211	0–20 mA
Measured value 0 mA	O212	1.00
Measured value 20 mA	O213	1.30
Active characteristic	K1	1
Edited characteristic	K2	1
Table option	K3	edit
Number of value pairs	K4	2
Support point	K5	1 ... 2
Measured value / display value	K6 / K7	1: 0 % / 1.00 2: 50 % / 1.50
Language version	S1	GER

**Note:**

Calibration is carried out in the % measuring range (the transmitter switches automatically). With the above setting, a density of e.g. 1.12 kg/l = 12 % must be selected. In individual cases, it may be necessary to adapt the calibration to a real sample. For this, a "single-point calibration" is sufficient.

For access to the CALIBRATION menu, please enter Code 22.

Coding	Field	Selection or range Factory setting	Display	Info
C	Function group <b>CALIBRATION</b>			
C1 (1)	Selection of calibration	<b>3 Pt = Three-point calibration (1)</b> Corr = Three-point correction (2) Edit = Edit calibration (3) Refl = Fitting with reflection effects (4) 1-Pt = Single-point calibration (5) Data = Calibration data (6)		For data set 1 (B4), only the "Data" function is accessible. The offset is reset with 3 Pt and Edit.
Immerse sensor in the calibration solution (sample 1).				Immerse the sensor so that there is sufficient distance to the tank wall (no reflection).
C111	Enter concentration of the first calibration solution	Value from last calibration		
Immerse sensor in the calibration solution (sample 2).				Immerse the sensor so that there is sufficient distance to the tank wall (no reflection).
C112	Enter concentration of second calibration solution	Value from last calibration		<b>C112 ≥ 1.1 × C111</b>
Immerse sensor in the calibration solution (sample 3 = original sample) .				Immerse the sensor so that there is sufficient distance to the tank wall (no reflection).
C113	Enter concentration of the third calibration solution	Value from last calibration		<b>C113 ≥ 1.1 × C112</b>

Factory settings are printed in **bold** face;  
base version does not include functions in *italic*.

Coding		Field	Selection or range Factory setting	Display	Info
	C114	Calibration status is displayed	o.k. E xxx		Cancel Warning:      Warning: Cancel  C161 ... C163
	C115	Store calibration results	<b>yes</b> no new		If C114 = E xxx, then only no or <b>new</b> (Exception: calibration warning E 84). If new, return to C. If yes/no, return to "Measurement".
C1 (2)		Selection of calibration	3 Pt = Three-point calibration (1) <b>Corr = Three-point correction (2)</b> Edit = Edit calibration (3) Refl = Fitting with reflection effects (4) 1-Pt = Single-point calibration (5) Data = Calibration data (6)		
	C121	Enter correct concentration of the third calibration solution	<b>Current value from C113</b> entire measuring range		In case of an unknown probe concentration, but with a definite dilution ( <sup>1</sup> / <sub>10</sub> ; <sup>1</sup> / <sub>3</sub> ; 1), the laboratory value is to be entered .
	C122	Calibration status is displayed	o.k. E xxx		
	C123	Store calibration results	<b>yes</b> no new		If C122 = E xxx, then only no or <b>new</b> (Exception: calibration warning E 84). If new, return to C. If yes/no, return to "Measurement".

Factory settings are printed in **bold** face;  
base version does not include functions in *italic*.

Coding	Field	Selection or range Factory setting	Display	Info
C1 (3)	Selection of calibration	3 Pt = Three-point calibration (1) Corr = Three-point correction (2) <b>Edit = Edit calibration (3)</b> Refl = Fitting with reflection effects (4) 1-Pt = Single-point calibration (5) Data = Calibration data (6)		If the individual samples were defined in the laboratory, you can correct the calibration here.
C131	Enter concentration of the first calibration solution	<b>Current value from C111</b> entire measuring range		
C132	Enter concentration of the second calibration	<b>Current value from C112</b> $C132 \geq 1.1 \cdot C131$		
C133	Enter concentration of the third calibration solution	<b>Current value from C113</b> $C133 \geq 1.1 \cdot C132$		
C134	Calibration status is displayed	o.k. E xxx		
C135	Store calibration results	<b>yes</b> no new		If C134 = E xxx, then only no or <b>new</b> (Exception: calibration warning E 84). If new, return to C. If yes/no, return to "Measurement".
C1 (4)	Selection of calibration	3 Pt = Three-point calibration (1) Corr = Three-point correction (2) Edit = Edit calibration (3) <b>Refl = Fitting with reflection effects (4)</b> 1 Pt = Single-point calibration (5) Data = Calibration data (6)		<b>Only for solutions <math>\leq 2</math> FNU / 5 ppm!</b> There is no effect of the installation in clear media

Factory settings are printed in **bold** face;  
base version does not include functions in *italic*.

Coding		Field	Selection or range Factory setting	Display	Info
	C141	Enter correct measured value	<b>0.0 NTU</b> 0.0 ... 2.0 NTU <b>0.0 FNU</b> 0.0 ... 2.0 FNU <b>0.0 ppm</b> 0.0 ... 5.0 ppm <b>0.0 mg/l</b> 0.0 ... 5.0 mg/l		Only for the ranges FNU, ppm, mg/l.
	C142	Calibration status is displayed	o.k. E xxx		
	C143	Store calibration results	<b>yes</b> no new		If C142 = E xxx, then only no or <b>new</b> (Exception: calibration warning E 84). If new, return to C. If yes/no, return to "Measurement".
C1 (5)		Select calibration	3 Pt = Three-point calibration (1) Corr = Three-point correction (2) Edit = Edit calibration (3) Refl = Fitting with reflection effects (4) <b>1-Pt = Single-point calibration (5)</b> Data= Calibration data (6)		For FNU: Adapter C164, C165.  For ppm, mg/l: up to 500 adapter C164, C165, then adapter C166.  For g/l, %: adapter C166. An existing basic calibration (three-point) is corrected by the single-point calibration.
	C151	Enter current calibration value	<b>Current measured value</b> Complete measuring range		
	C152	Calibration status is displayed	o.k. E xxx		
	C153	Store calibration results	<b>yes</b> no new		If C152 = E xxx, then only no or <b>new</b> (Exception: calibration warning E 84). If new, return to C. If yes/no, return to "Measurement".

Factory settings are printed in **bold** face;  
base version does not include functions in *italic*.

Coding	Field	Selection or range Factory setting	Display	Info
C1 (6)	Selection of calibration	3 Pt = Three-point calibration (1) Corr = Three-point correction (2) Edit = Edit calibration (3) Refl = Fitting with reflection effects (4) 1-Pt = Single-point calibration (5) <b>Data = Calibration data (6)</b>		
C161	Calibration point 1 is displayed	Comparison value		Deviation relative to standard sensor (= 100 %)
C161	Calibration point 2 is displayed	Comparison value		Deviation relative to standard sensor (= 100 %)
C161	Calibration point 3 is displayed	Comparison value		Deviation relative to standard sensor (= 100 %)
C164	Slope 1 is displayed	Current value		Slope of characteristic 1 of the sensor
C164	Slope 2 is displayed	Current value		Slope of characteristic 2 of the sensor
C166	Conversion factor is displayed	Current value		Conversion factor of internal turbidity units into the displayed unit

Factory settings are printed in **bold** face;  
base version does not include functions in *italic*.

### 5.11 Offset

The settings in the OFFSET function group can be used to calibrate the measurement to a reference measurement. This requires a linear shift of all measured values, i.e., the adjustment is determined for one measured value, and all the others are calculated using the same offset.



**Note:**

You can either edit offset or slope. During offset editing, a previous edited slope is reset to the factory setting.

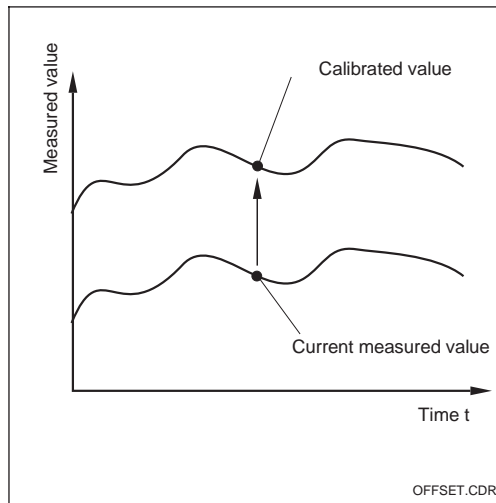

Fig. 5.9 Offset

Coding	Field	Selection or range Factory setting	Display	Info
V	Function group <b>OFFSET</b>			
V1	Enter absolute value	<b>Current measured value</b>		
V2	Enter offset	<b>Current offset</b>		
V3	Calibration status is displayed	o.k. E xxx		
V4	Store offset	<b>yes</b> no new		If V3 = E xxx, then only no or <b>new</b> . If new, return to V. If yes/no, return to "Measurement".

Factory settings are printed in **bold** face;  
base version does not include functions in *italic*.

### 5.12 Slope

With the settings in the function group SLOPE, a measured value can be adapted to a reference value. All measured values are proportionally adapted over the entire measuring range according to this change.

Example:

The displayed measured value is 2.5 g/l. It is adapted to the reference value of 2.0 g/l by means of the slope function. The change is 20%, i.e. all measured values are reduced by 20% over the entire measuring range. An OFFSET being edited before is reset to the factory setting. In contrast to the one-point calibration, the edited slope can be reset by setting the slope factor to 1.0.

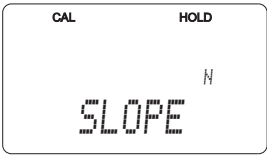
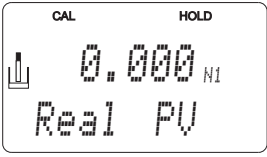
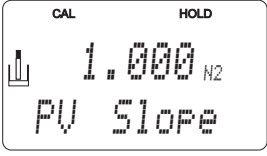
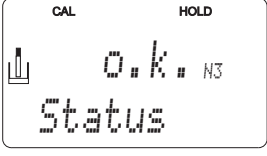
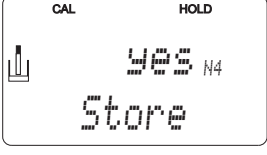
Coding	Field	Selection or range Factory setting	Display	Info
N	Function group SLOPE			Initial display of function group SLOPE.
N1	Enter absolute value	<b>Current measured value</b>		
N2	Enter slope	<b>Current slope</b>		
N3	Status is displayed	o.k. E xxx		
N4	Store slope	<b>yes</b> no new		If V3 = E xxx, then only no or <b>new</b> . If new, return to V. If yes/no, return to "Measurement".

Factory settings are printed in **bold** face;  
base version does not include functions in *italic*.

## 6 Interfaces

For instruments equipped with a communication interface, please refer to separate operating instructions BA 208e00 (HART®) or BA 209e00 (PROFIBUS®).

## 7 Maintenance and troubleshooting

### Maintenance:

Please take all measures in due time which will guarantee the safety of operation and reliability of the entire measuring system.

Maintenance of OUM 223 / 253 comprises:

- Calibration (see chap. 5.10)
- Cleaning of assembly and sensor
- Checking of cables and connections

### Troubleshooting

Determination and elimination of the cause of the problem in the case of an operating fault. Troubleshooting refers to measures that can be performed without intervention in the instrument (for instrument defects, see chap. 8, Repairs). Troubleshooting of the OUM 223/253 and the measuring system is performed with the aid of the troubleshooting table in chap. 7.1.



#### Warning:

- Please be aware of effects work performed on the instrument might have on the process control system or the process itself.
  
- When removing the sensor during maintenance or calibration, please consider potential hazards due to pressure, high temperatures and contamination.



#### Note:

- Please contact your support office for queries.

### 7.1 Troubleshooting common problems

Error	Possible cause	Remedy	Equipment need, spare parts, information
Instrument cannot be operated, value 9999	– Operation locked	Press simultaneously the CAL and MINUS keys	See chap. 4.3
Display value 0.0, and error message E008 "Sensor" and display — in A4	– Sensor / sensor cable defective – Instrument input defective – Break in sensor extension line – Data transfer error – Incorrect sensor connection	Test with new or with different functional sensor Replace MKT1 module for testing Check junction boxes and line. Check sensor supply. Replace LSGA (AC power supply unit or L2GD (DC power supply unit) module for testing Check connection	CUS 31 or 41 sensor (either type is suitable for rough function test) S. spare parts list in chap. 8.2.4/8.3.4 Measuring point test in chap. 8.6.1  See spare parts list in chap. 8.2.4 / 8.3.4  Connection see chap. 3.4 and 3.5
Display value 0.0	– Sensor completely blocked	Clean optics	Use spray cleaning or wiper
Fixed, incorrect measured value	– Impermissible instrument operating state (no response to key actuation)	Switch instrument off and back on	EMV problem: check line routing if problem persists, check for possible sources of interference.
Measured value fluctuates	– Measuring cable interference – Signal output line interference – Irregular flow rate / turbulence / air bubbles / big solids particles	Connect cable screen acc. to connection diagram (not grounding) – check line routing, – try separate line routing, grounding screen to SPS/PLS Choose better place of installation or eliminate turbulences. Possibly use large measured value damping factor.	See chap. 3.4 and 3.5  Separate signal output, meas. input and supply lines  Measured value damping see field A5

Error	Possible cause	Remedy	Equipment need, spare parts, information
Display value implausible / no or creeping change of display	<ul style="list-style-type: none"> <li>– No or incorrect sensor calibration</li> <li>– Sensor soiled</li> <li>– Wiper rubber defective</li> <li>– Sensor installed in “dead” zone or air cushion in assembly or flange</li> <li>– Incorrect sensor orientation</li> </ul>	<p>Calibration with original sample required for concentration or solids concentration</p> <ul style="list-style-type: none"> <li>– Clean sensor</li> <li>– Use spray cleaning</li> <li>– User wiper version</li> </ul> <p>Replace wiper arm</p> <p>Check installation conditions, move sensor in area with optional flow conditions. Caution if installed in horizontal lines!</p> <p>Orient sensor:</p> <ul style="list-style-type: none"> <li>– Measuring surface should face flow in normal media.</li> <li>– Orient meas. surface at 90° to flow in media with high solids concentration</li> </ul>	<p>See chap. 5.10</p> <ul style="list-style-type: none"> <li>– Remove coarse coats mit brush</li> <li>– Remove carbonates and similar coats with 3% hydrochlorid acid</li> <li>– Remove organic coats and grease with oxidation agents and / or grease solvents.</li> </ul> <p>See instructions of assembly used for spray cleaning</p> <p>Retrofitting possible: “wiper retrofitting” service kit 50089254 “Wiper arm” service kit 50089252</p> <p>Frontal “bombardment” of measuring surface with highly viscous solids may result in an adhering coating.</p>
Incorrect temperature value	<ul style="list-style-type: none"> <li>– Temperature sensor defective</li> </ul>	If temperature display is required: replace sensor	Turbidity measurement itself does not require temperature meas.
Controller or timer cannot be activated	<ul style="list-style-type: none"> <li>– No relay module installed</li> </ul>	Install LSR1-2 or LSR1-4 module	See chap. 8.2 and 8.3
Controller / limit contactor does not work	<ul style="list-style-type: none"> <li>– Controller switched off</li> <li>– Controller in “Manual / Off” mode</li> <li>– Pickup delay setting too long</li> <li>– “Hold” function active</li> </ul>	<p>Activate controller</p> <p>Choose “Auto” or “Manual/On” mode</p> <p>Disable or shorten pickup delay</p> <p>“Autom. hold” during calibration, “hold” input activated; “hold” via keyboard active</p>	<p>See chap. 5.5 or fields R2xx</p> <p>Keyboard, REL key</p> <p>See fields R2xx</p> <p>See fields S2 to S4</p>
Controller / limit contactor works continuously	<ul style="list-style-type: none"> <li>– Controller in “Manual / On” mode</li> <li>– Dropout delay setting too long</li> <li>– Control loop interruption</li> </ul>	<p>Set controller to “Manual / Off” or “Auto”</p> <p>Shorten dropout delay</p> <p>Check measured value, current output or relay contacts, actuators, chemical supply</p>	<p>Keyboard, REL and AUTO keys</p> <p>See fields R2xx</p>
No turbidity current output signal	<ul style="list-style-type: none"> <li>– Line open or short-circuited</li> <li>– Total load in current loop excessive (<math>&gt; 500 \Omega</math>)</li> <li>– Output defective</li> <li>– Instrument with PROFIBUS-PA/-DP</li> </ul>	<p>Disconnect line and measure directly on instrument</p> <p>Disconnect line and measure directly on instrument</p> <p>See diagnosis table in chap. 8.1</p> <p>PA-/DP instruments have no current output!</p>	<p>mA meter 0–20 mA DC</p> <p>Ohmmeter</p>
Fixed current output signal	<ul style="list-style-type: none"> <li>– Current simulation active</li> <li>– Processor system out of sync</li> </ul>	<p>Switch off simulation</p> <p>Switch instrument off and back on</p>	<p>See field O2(2)</p> <p>EMV problem: check installation if problem persists</p>
Incorrect current output signal	<ul style="list-style-type: none"> <li>– Incorrect current assignment</li> <li>– Total load in current loop excessive (<math>&gt; 500 \Omega</math>)</li> </ul>	<p>Check current assignment: 0–20 mA or 4–20 mA?</p> <p>Disconnect output and measure directly on instrument</p>	<p>Field O2(1), O2(3) for table</p> <p>Ohmmeter</p>
Current output table not accepted	<ul style="list-style-type: none"> <li>– Value interval too small</li> </ul>	Use sensible intervals	
No temperature output signal	<ul style="list-style-type: none"> <li>– Instrument only has one current output</li> </ul>	Refer to nameplate for variant, change LSCH-x1 module if nec.	LSCH-x2 module, see chap. 8.2.4 and 8.3.4

Error	Possible cause	Remedy	Equipment need, spare parts, information
Chemoclean function not available	<ul style="list-style-type: none"> <li>– No relay module (LSR1-x) or nur LSR1-2 installed</li> </ul>	Install LSR1-4 module. Chemoclean is enabled via release code supplied by manufacturer with Chemoclean upgrade	LSR1-4 module, see chap. 8.2.4 and 8.3.4
Plus package functions not available	<ul style="list-style-type: none"> <li>– Plus package not enabled (enable with code that depends on serial number and is received from the manufacturer with order or Plus package)</li> </ul>	<ul style="list-style-type: none"> <li>– Plus package upgrade: code received from manufacturer ⇒ enter</li> <li>– Following replacement of defective LSCH/LSCP module: first enter instrument serial number (see nameplate) manually, then enter code</li> </ul>	Detailed description see chap. 8.3.5

## 7.2 Troubleshooting using the error messages

Display and select error messages by pressing the MINUS key.

Error no.	Display	Measures	Contact		Error current		Cleaning trigger	
			Fact	User	Fact	User	Fact	User
E001	EEPROM memory error	Switch instrument off and back on, return instrument to your local sales agency for repair or replace instrument.	yes		no		—	—*
E002	Instrument not calibrated, calibration data invalid, no user data invalid (EEPROM error).	Load software compatible with hardware. Load measuring parameter specific instrument software.	yes		no		—	—*
E003	Download error	Invalid configuration. Repeat download, check optoscope.	yes		no		—	—*
E004	Instrument software version not compatible with module hardware version	Load software compatible with hardware. Load measuring parameter specific instrument software.	yes		no		—	—*
E007	Transmitter malfunction Software not compatible with hardware (transmitter)		yes		no		—	—*
E008	Sensor or sensor connection defective	Check sensor and sensor connection (Service)	yes		no		no	
E026	Wiper error	Check wiper and test function using manual control if necessary	yes		no		no	
E045	Calibration aborted	Repeat calibration	no		no		—	—*
E055	Below main parameter measuring range	Check measurement and connections; check instrument and measuring cable with simulator if necessary.	yes		no		no	
E057	Main parameter measuring range exceeded	Check measurement, control and connections	yes		no		no	
E059	Below temperature measuring range		yes		no		no	
E061	Temperature measuring range exceeded		yes		no		no	
E063	Below current output range 1	Check configuration	yes		no		no	
E064	Current output range 1 exceeded	Check measured value and current assignment	yes		no		no	
E065	Below current output range 2		yes		no		no	
E066	Current output range 2 exceeded		yes		no		no	
E067	Set point exceeded controller 1	Check configuration.	yes		no		no	
E068	Set point exceeded controller 2		yes		no		no	
E069	Set point exceeded controller 3	Check configuration	yes		no		no	
E070	Set point exceeded controller 4		yes		no		no	
E079	Measured value outside concentration table	Clean sensor; check tables	yes		no		no	

Error no.	Display	Measures	Contact		Error current		Cleaning trigger	
			Fact	User	Fact	User	Fact	User
E080	Parameter range for current output 1 range too small	Decrease current output spreading	no		no		—	—*
E081	Parameter range for current output 2 range too small	Decrease current output spreading	no		no		—	—*
E084	Calibration warning	Calibration data are within limits but deviate from standard values by a factor of more than two	no		no		no	
E100	Current simulation yes	Switch off current simulation	no		no		—	—*
E101	Service function yes	Switch instrument off and back on	no		no		—	—*
E102	Relais simulation yes	Check relay configuration	no		no		—	—*
E106	Download yes	Wait for download to end	no		no		—	—*
E116	Download error	Repeat download	no		no		—	—*
E152	PCS alarm	Check sensor and connection, maintain or replace	no		no		no	
E153	Offset	Adjustment range exceeded	no		no		no	
E154	Below lower alarm threshold for period exceeding alarm delay	If necessary perform manual reference measurement. Repair sensor and recalibrate	yes		no		no	
E155	Upper alarm threshold exceeded for period exceeding alarm delay		yes		no		no	
E156	Actual value undershoots monitoring value for longer than the set permissible maximum period		yes		no		no	
E157	Actual value exceeds monitoring value for longer than the set permissible maximum period		yes		no		no	
E162	Dosage stop	Check settings in CURRENT INPUT or CHECK function group.	yes		no		no	
E171	Flow in main stream too low or zero	Restore flow.	yes		no		no	
E172	Switch-off limit for current input exceeded	Check process variables at sending measuring instrument.	yes		no		no	
E173	Current input < 4 mA	Check process variables at sending measuring instrument. Change range assignment if required.	yes		no		no	
E174	Current input > 20 mA	Check process variables at sending measuring instrument. Change range assignment if required.	yes		no		no	

\* If this error is present, the cleaning function cannot be started.  
(Field F8 does not exist for this error.)

## 8 Diagnosis and corrective maintenance

### Diagnosis

- Diagnosis refers to the identification of instrument malfunctions and defects.

### Corrective maintenance:

- replacement of parts diagnosed to be defective;
- testing of instrument and measuring system function;
- restoration of complete functionality.

Diagnosis based on the error table below and depending on difficulty and measuring equipment at hand is to be performed by:

- trained operator personnel
- operator's electricians
- company responsible for system installation/ operation
- your Service.

Select the required spare parts using the tables in chap. 8.2 and 8.3.



#### Warning:

- Disconnect the instrument from the power source before opening it up. Work with live lines may only be performed by trained electricians.
- Switched contacts may be supplied from separate circuits. These circuits must also be de-energized before work on the terminals is performed.



#### Caution: ESD!

- Electronic components are sensitive to electrostatic discharges. Personal protective measures, such as discharge via PE or permanent grounding using a wrist strap, are to be taken.
- For your own safety, use only original spare parts. Original parts will guarantee functionality, accuracy and reliability after repairs.

### 8.1 Diagnosis

The table below will help you diagnose problems and provides information about spare parts required. Note on the required spare parts. You can find information concerning the exact spare part designations and the installation of these parts in chap. 8.2.3 and 8.3.3.

Error	Possible cause	Tests and / or remedial measures	Equipment, spare parts, personnel
Display dark, no LEDs active	<ul style="list-style-type: none"> <li>– No mains voltage</li> <li>– Wrong supply voltage / voltage too low</li> <li>– Connection fault</li> <li>– Instrument fuse defective</li> <li>– Power supply unit defective</li> <li>– Controller defective</li> <li>– OUM 253: ribbon cable Pos. 310 loose or defective</li> </ul>	<ul style="list-style-type: none"> <li>Check if mains voltage is available</li> <li>Compare mains voltage and rating on nameplate</li> <li>Terminal not tightened; insulation clamped in terminal; wrong terminal used</li> <li>Replace fuse, first compare mains voltage and rating on nameplate</li> <li>Replace power supply unit, using correct variant</li> <li>Replace controller, using correct variant</li> <li>Check ribbon cable, replace if necessary</li> </ul>	<ul style="list-style-type: none"> <li>Electrician / e.g. multimeter</li> <li>Operator (utility company specification or multimeter)</li> <li>Electrician</li> <li>Electrician / see drawings in chap. 8.2.1 and 8.3.1 for corrected fuse</li> <li>On-site diagnosis by your Service (test module LSGx Lrequired)</li> <li>On-site diagnosis by your Service (test module LSCxx Lrequired)</li> <li>See spare parts for OUM 253</li> </ul>
Display dark, but LED(s) active	Controller defective (Module: LSCH/LSCP)	Replace controller	On-site diagnosis by your Service (test module LSCxx required)

Error	Possible cause	Tests and / or remedial measures	Equipment, spare parts, personnel
Display shows measured values but – value does not change and / or – instrument cannot be operated	– Instrument or module not properly installed in instrument – Impermissible operating system state	OUM 223: Reinstall module OUM 253: Reinstall display module Switch instrument off and back on	Refer to assembly drawings in chapters 8.2.1 and 8.3.1. Possible EMC problem: if problem persists, call your Service to have installation checked.
Instrument gets hot	– Incorrect voltage / too high – Power supply unit defective	Compare mains voltage and rating of nameplate Replace power supply unit	Correct voltage setting, see chap. 8.4.1 / 8.5.1. Can only be diagnosed by your Service.
Incorrect measured turbidity and / or temperature value	– Transmitter module defective (module: MKT1). Please perform tests and take measures according to chap. 7.1 to eliminate the sensor or wiring as the cause of the problem – Data transfer fault – Data transfer problem (EMC) – Wrong sensor cable / cable too long	Test measuring inputs: Sensor simulation is not possible, check with new or other sensor  Replace LSGA module (AC power supply unit) or LSGD (DC power supply unit) Check line routing. Separate sensor line from supply lines Max. line length with extension is 200 m; use only calbe type CYK 8	If test fails: replace module (using correct variant), refer to exploded views in chap. 8.2.1 and 8.3.1.  If module tests out OK: check peripherals once more. Spare parts list see chap. 8.4.4 or 8.5.4.  Connect sensor line screen to “S” terminal, do not ground.
Current outputs / incorrect current	– Not calibrated correctly – Load excessive – Shunt / short-circuit to frame in current loop  – Incorrect mode of operation	Test with built-in current simulation, connecting mA meter directly to current output  Check whether 0–20 mA or 4–20 mA has been selected	If simulation value is incorrect: recalibration at factory or new LSCxx module required.  If simulation value is correct: check current loop for load and shunts.
No current output signal	– Current output stage defective (module: LSCH/LSCP)	Test with built-in current simulation, connecting mA meter directly to current output. First disconnect current output line completely for safety	If test fails: Replace controller (using correct variant)
Additional relays do not work	– OUM 253: ribbon cable Pos. 320 loose or defective	Make sure ribbon cable is properly connected, replace cable if nec.	See Spare parts OUM 253 F
Only 2 additional relays can be used	– Relay module LSR1-2 with 2 relays installed	Convert to LSR1-4 with 4 relays	Operator or your Service
Enhanced functions (Plus package) not available	– No or incorrect release code used – Incorrect serial number of instrument stored in LSCH/LSCP module	If upgraded: verify that correct serial number has been used to order Plus package Check whether serial number on nameplate matches with stored serial number (can be read in field S8).	Handled by your Sales  Serial number stored in LSCH/LSCP module is required to enable Plus package.
Enhanced functions (Plus package and / or Chemoclean) are not available after replacement of LSCH-/LSCP module	– Plus package or Chemoclean has not been enabled with release codes.	For new LSCH / LSCP, the instrument serial number can be entered <b>once</b> in fields E114 to E116. Next step is to enter release codes for Plus package and/or Chemoclean.	A detailed description can be found in chap. 8.3.5.
No HART or PROFIBUS interface function	– Wrong controller  – Wrong software – Bus problem	HART: LSCH-H1 or -H2 PROFIBUS-PA/-DP: LSCP-PA/-DP module, see field E112 SW version see field E111 Remove some instruments and repeat testing	Replace controller; operator or your Service  Contact E-H Service for support

## 8.2 Corrective maintenance of OUM 223

### 8.2.1 Exploded view

223\_EX02.CDR

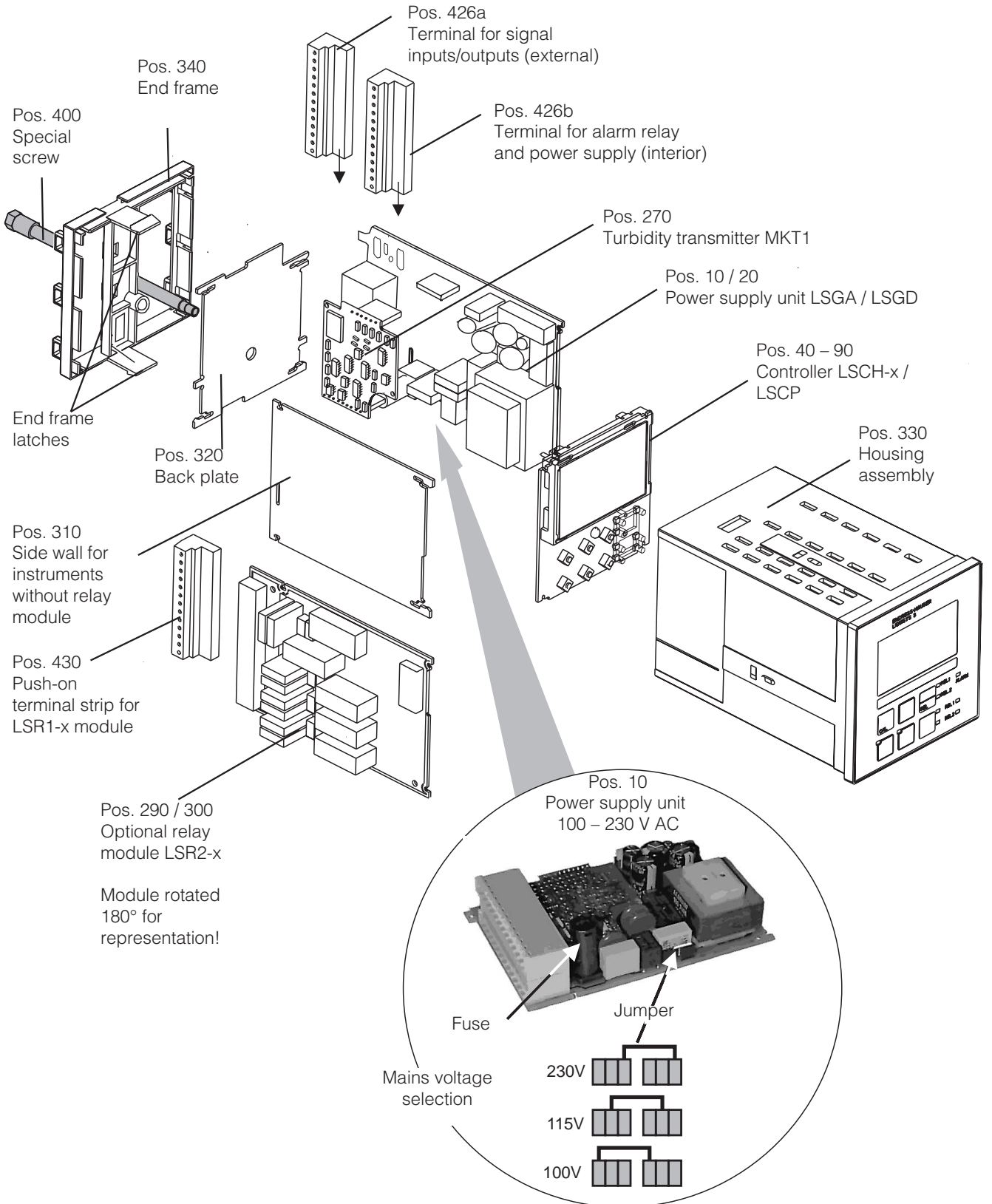

### 8.2.2 Disassembly of OUM 223

- Consider potential effects on process when removing the instrument from service!
- Before opening, make sure the instrument is voltage-free.
- First pull off the terminal block (Pos. 426b) on the rear of the instrument.
- First pull off the terminal blocks (Pos. 426a and if necessary 430) on the rear of the instrument. You can now dismantle the instrument.
- Press the latches of the end frame (Pos. 340) inwards and pull off the frame towards the rear.
- Loosen the special screw (Pos. 400) by turning it counterclockwise.
- Remove the complete electronics block from the housing. The modules are plugged together mechanically and can be easily separated:
  - Pull the controller / display module forwards
  - Gently pull out the backplane latches (Pos. 320) outwards slightly to remove the side modules.
- Removing the turbidity transmitter (Pos. 270):  
Pull off the module towards the top.

### 8.2.3 Assembly of OUM 223

- Reverse the dismantling sequence for assembly.
- Hand-tighten the special screw without using a tool.
- Incorrect assembly is not possible!  
An module block which has been plugged together incorrectly cannot be inserted into the housing.

## 8.2.4 Spare parts for OUM 223

Position	Designation	Name	Function or content	Order number
10	Power supply unit	LSGA	100/115/230 V AC	51500317
20	Power supply unit	LSGD	24 V AC + DC	51500318
40	Controller	LSCH-S1	1 current output	51501228
50	Controller	LSCH-S2	2 current outputs	51501229
60	Controller	LSCH-H1	1 current output + HART	51501230
70	Controller	LSCH-H2	2 current outputs + HART	51501231
80	Controller	LSCP-PA	PROFIBUS-PA / no current output.	51501232
90	Comntroller	LSCP-DP	PROFIBUS-DP / no current output	51502499
270	Turbidity transmitter	MKT1	Turbidity + temperature	51501209
290	Relay module	LSR2-2	2 Relays	51500320
290	Relay module	LSR2-2i	2 Relays + current input 4..20 mA	51504304
300	Relay module	LSR2-4	4 Relays	51500321
300	Relay module	LSR2-4i	4 Relays + current input 4..20 mA	51504305
310	Side panel		Kit with 10 parts	51502124
340	End frame PROFIBUS-DP		End frame with D-Submin plug-in connector	51502513
330, 400	Housing module		Housing with front membrane, Sensor plungers, Seal, Special screw, Clamp tappets, Connection and nameplates	51501075
310, 320, 340, 400	Mechanical parts housing		Backplate, Side wall, End frame, Special screw	51501076
426a, 426b	Complete terminal strip set, Standard + HART		Terminal strip set Standard + HART, Inputs/outputs, power supply, alarm relay	51501205
426a, 426b	Complete terminal strip set, PROFIBUS-PA		Terminal strip set PROFIBUS-PA, Inputs/outputs, Power supply, Alarm relay	51502128
426a, 426b	Complete terminal strip set, PROFIBUS-DP		Terminal strip set PROFIBUS-DP, Inputs/outputs, Power supply, Alarm relay	51502491
430	Terminal strip		Terminal strip for relay module	51501078

### 8.3 Corrective maintenance of OUM 253

#### 8.3.1 Exploded view

253\_EX02.CDR

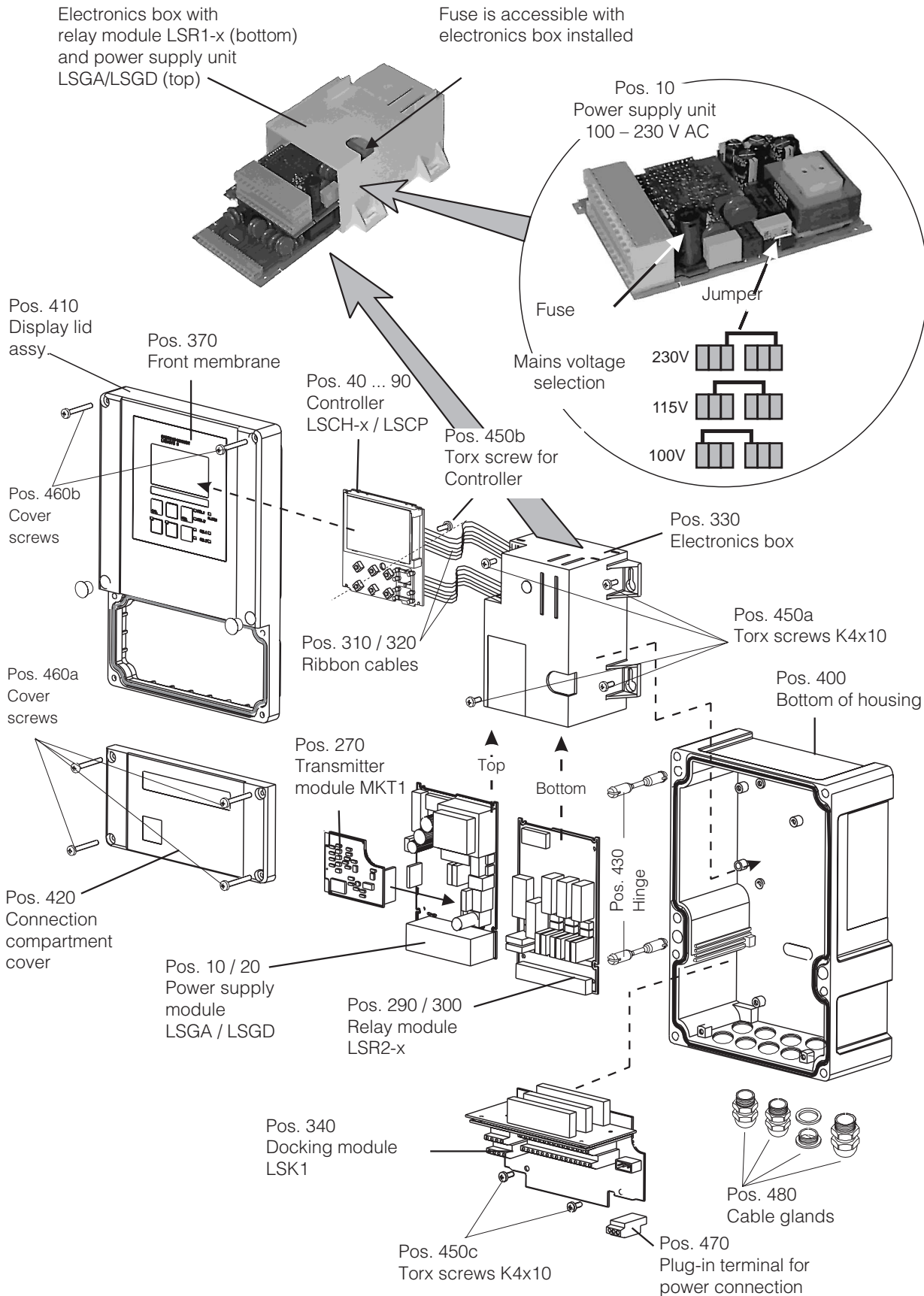

### 8.3.2 Disassembly of OUM 253

- Before opening, make sure the instrument is voltage-free.
- Open and remove the connection compartment cover (Pos. 420).
- Remove the network terminal (Pos. 70).
- Open the display cover (Pos. 410) and loosen the ribbon cable (Pos. 310 / 320) on the electronics box side (Pos. 330).
- Removal of electronics box (Pos. 330):  
Loosen screws (Pos. 450a) in the bottom of the housing 2 revolutions, then slide entire box backward and remove towards the top. Make sure that the module catches do not come unlatched while you push the electronics box back!
- Now bend the module latches outward and remove the module(s).
- Dismantling the controller (Pos. 40):  
Loosen screw (Pos. 450b) in the display lid.
- Expansion of the docking module (Pos. 340):  
Loosen screws (Pos. 450c) in the bottom of the housing and remove entire module towards the top.
- Removing the transmitter (Pos. 270):  
Simply pull off the module towards the top.

### 8.3.3 Assembly of OUM 253

- Insert the module(s) in the electronics box guide rails carefully and latch into the lateral lugs in the box.
- You cannot assemble the instrument incorrectly!  
Modules inserted in the electronics box incorrectly are not operable since the ribbon cables cannot be inserted.
- Make sure that the cover gaskets are intact since they are required to guarantee protection class IP 65.

**8.3.4 Spare parts for OUM 253**

Position	Designation	Name	Function or content	Order number
10	Power supply unit	LSGA	100/115/230 V AC	51500317
20	Power supply unit	LSGD	24 V AC + DC	51500318
40	Controller	LSCH-S1	1 current output	51501228
50	Controller	LSCH-S2	2 current outputs	51501229
60	Controller	LSCH-H1	1 current output + HART	51501230
70	Controller	LSCH-H2	2 current outputs + HART	51501231
80	Controller	LSCP-PA	PROFIBUS-PA / no current output.	51501232
90	Controller	LSCP-DP	PROFIBUS-DP / no current output	51502499
270	Turbidity transmitter	MKT1	Turbidity + temperature	51501209
290	Relay module	LSR2-2	2 Relays	51500320
290	Relay module	LSR2-2i	2 Relays + current input 4..20 mA	51504304
300	Relay module	LSR2-4	4 Relays	51500321
300	Relay module	LSR2-4i	4 Relays + current input 4..20 mA	51504305
370, 410, 420, 430, 460	Housing cover		Display cover, connection compartment cover, front membrane, Hinge, Cover screws, Small parts	51501068
400, 480	Bottom of housing		Bottom, cable glands	51501072
330, 340, 450	Internal housing parts		Docking module, empty electronics box, small parts	51501073
310, 320	Ribbon cables		2 ribbon cables	51501074
430	Hinges		2 pairs of hinges	51501069
470	Terminal strip		Terminal strip for power connection	51501079

### 8.3.5 Special case: Replacement of controller



#### Note:

- After controller replacement all the editable data are reset to the factory settings.
- The serial number can only be entered – and **only once** – in the case of a new module from the factory with serial number 0000! Make sure that your entry is correct before confirming with ENTER! Entry of an incorrect code will prevent the enhanced functions from being enabled. An incorrect serial number can only be corrected at the factory.

Proceed as described below after controller replacement:

- If possible, record the user settings of the instrument, e.g.:
  - Measuring range and configuration setting
  - Turbidity and temperature current assignments
  - relay functions selected
  - limits/controller settings
  - cleaning settings
  - monitoring functions
  - interface parameters

- Disassemble the instrument as described in chapters 8.2.2 and 8.3.2..
- Refer to the part no. of the central module to determine whether the new module has the same part no. as the old one.
- Reassemble the instrument with the new module as described in chap. 8.2.3 and 8.3.3.
- Start up the instrument and test its basic functions (e.g. meas. value and temperature display, operation via keyboard).
- Enter the instrument serial number:
  - Read the serial number (“ser-no.”) of the instrument from the nameplate.
  - Enter this number in the fields E115 (year, one-digit), E116 (month, one-digit), E117 (sequence number, four-digit).
  - Field E118 displays the complete number for verification; acknowledge with ENTER or abort and re-enter.
- Verify that the Plus package is enabled (e.g. by accessing function group CHECK / Code P) or the Chemoclean function.
- Check the Plus package release (e.g. by opening the function group CHECK / Code P) or the Chemoclean function.
- Restore the user settings of the instrument.

## 8.4 Spare parts orders

Spare parts are to be ordered from your local Sales Agency. For this, refer to the order numbers in chapters 8.2.4 and 8.3.4.

- instrument order code
- serial number (ser-no.)
- software version, if possible

To be on the safe side, you should **always** specify the following data with spare parts orders:

The order code and serial number are on the nameplate.  
The software version is displayed in field E111 when the instrument processor system is functional.

## 8.5 Service aids “Optoscope” with “Scopeware”

In connection with the “Scopeware” software, the optoscope offers the following possibilities, **with** the need to disassemble or open the transmitter and **without** a galvanic connection to the device:

- Documentation of the instrument settings in conjunction with Commuwin II
- Software update by the service technician
- Upload/download a hex dump to duplicate configurations.

Handling and operation are described in the optoscope operating instructions. The user-friendly Windows software required for the PC or laptop is contained in the scope of supply.

The optoscope is supplied in a sturdy case with all the accessories required.

**Order number of optoscope: 51500650**

The optoscope serves as an interface between the transmitter and PC / laptop. Information is exchanged on the instrument-side using the optical interfaces of the transmitter and to the PC / laptop using the interface RS 232.

## 8.6 Corrective maintenance of measuring system

### 8.6.1 Turbidity transmitter

The sensors OUS 31 and OUS 41 cannot be simulated as they contain the complete data processing and all the measured values are transmitted using the digital interface RS 485 to OUM 223 / 253. Therefore a functional sensor is required for the measuring point test.

#### Method for testing a measuring point:

- Check that device is operable and that the display reacts appropriate, e.g. by pressing the PLUS key.
- Check the current outputs by carrying out a current simulation (Field O22).

- Measure the sensor operating voltage: approx. 10 ... 16 V at terminals 87 (+) and 88 (-).
- The cause for a defective voltage may be present either at the device or at the sensor. Therefore, the next thing you should do is
  - connect a new or a different sensor.
  - If the function is now o.k. -> Sensor defective.
  - If the sensor operating voltage is still to low -> replace power supply module LSGA/LSGD (Pos. 10 / 20, check the required version).
- Sensor voltage o.k., but no measured turbidity value even with a new sensor: -> Replace transmitter module MKT1.

#### Cleaning the front panel

To clean the front panel, only use standard cleaning agents.

The front panel is resistant to the following cleaning agents (acc.

- Isopropanol
- Thinned acids (3 %)
- Thinned alkalis (5 %)
- Ester
- Hydrocarbons
- Ketone
- Household cleaners



#### Caution!

Do not use any concentrated mineral acids or alkalis, benzyl-alcohol, methylene chloride or high-pressure water vapour at over 100 °C.

### 8.6.2 Turbidity sensors OUS 31 / 41

The sensors OUS 31 / 41 contain their own digital signal processor and communicate with the turbidity measuring instrument via an interface RS 485. All the sensor data (factory calibration data and customer calibration data) are permanently saved in the sensor.

You can find detailed information on these sensors in the "Technical Information OUS 31 / OUS 31-W" TI 176e00 or in "Technical Information Solid matter sensor OUS 41 / OUS 41-W" TI 177e00.

When replacing a sensor, check the following:

- **Replacing the sensor OUS 31-xxA or OUS 41**  
All the calibration data is saved in the sensor. When using the original data records ("read only"), no calibration is necessary after sensor replacement. Matter-specific calibrations must be repeated.
- **Replacing the sensor OUS 31-xxE or OUS 31-xxS**  
All the factory calibration data is saved in the sensor. The sensor and the assembly are calibrated together. No additional calibration is required for applications with pure or ultrapure water, if the sensor **and** the assembly are replaced together. The calibration data of the sensor is transferred automatically to the measuring instrument.

### 8.6.3 Assembly

Refer to the assembly operating instructions for maintenance and troubleshooting! For the OUS 31/41, you can use:

#### **Basin and channel**

- Suspended assembly holder CYH 101 and basin wall bracket CYY 106  
Technical Information TI 092e00
- Assembly OYA 611  
Operating manual BA 166e00
- Sensor fixing bracket RM  
Operating manual BA 205e00

#### **Flow**

- Flow assembly OUA 250  
Operating manual BA 096e00
- Welding socket with adapter OUA 120-B

#### **Retractable assembly**

- OUA 461  
Operating manual BA 134e00

#### **Pure and ultrapure water applications**

- OUS 31-xxE: contains special flow assembly without gas bubble trap
- OUS 31-xxS: contains special flow assembly with gas bubble trap

## 9 Accessories

### Mounting accessories

- Weather protection cover OYY 101  
For mounting on field housing, for outdoor installation.  
Dimensions (H × W × D):  
320 × 300 × 270 mm  
Material: Stainless steel SS 304  
Order no.: OYY 101-A
- Universal upright post OYY 102  
Square tube for mounting of field housing.  
Dimensions (H × W × D):  
1495 × 60 × 60 mm  
Material: Stainless steel SS 304  
Order no.: OYY 102-A

### Sensors

- **OUS 31 / 31 W**  
pH/ redox combination electrode with PTFE diaphragm, with gel filling, usable at up to 6 bar.  
Technical Information TI 028e00
- **OUS 41 / 41 W**  
Sterilisable pH /redox electrode with double-chamber reference and integrated bridge electrolyte.  
Technical Information TI 245e00

### Spare parts for OUS 31 and OUS 41

- Service kit for wiper operation cpl. (upgrade or replacement)  
Order no.: 50089254
- Service Kit for seal (for wiper extension, contains 5 sets)  
Order no.: 50089253
- Service Kit for wiper arm (with rubber and mounting material, contains 3 sets)  
Order no.: 50089252
- Measuring cable 7 m terminated, with housing upper section and screw union  
Order no.: 50088167
- O-ring 28 × 3.5 mm (Seal for G 1 pipe installation)  
Order no.: 50051753

### Accessories for OUM 253 CSA version

- NPT adapter set  
Order no.:

### Connection accessories

- **Extension cable CYK 8, metre goods**  
Unterminated measuring cable for turbidity sensors OUS 31 and OUS 41  
Order no.: 50089633
- **Extension cable CYK 8, 50 m**  
Terminated measuring cable for turbidity sensors OUS 31 and OUS 41.  
Order no.: 51500830
- **Junction box VBM**  
Junction box for extending the measuring cable connection between sensor and instrument. Pg 13.5 cable entries.  
Material: cast aluminium;  
Ingress protection: IP 65  
Order no.: 50003987
- **Junction box RM**  
Junction box for extending the measuring cable connection between sensor and instrument. Pg 13.5 cable entries.  
Material: cast aluminium;  
Ingress protection: IP 65  
Order no.: 51500832

### Assemblies

- **OYA 611**  
Immersion assembly for turbidity sensors, unpressurised.  
Technical Information TI 166e00
- **OUA 250**  
Flow assembly for turbidity sensors, applicable at up to 6 bar  
Technical Information TI 096e00
- **OUA 461**  
Manually replacable assembly for turbidity sensors, applicable at up to 1 bar  
Technical Information TI 134e00

**Instrument upgrade**

(Order only possible with serial number of relevant device)

- Plus package  
Order no.: 51500385
- ChemoClean  
Order no.: 51500963
- Two-relay card (standard version)  
Order no.: 51500320
- Two-relay card (CSA version)  
Order no.: 51511446
- Four-relay card (standard version)  
Order no.: 51500321
- Four-relay card (CSA version)  
Order no.: 51511447
- Two-relay card with current input  
(standard version / CSA version)  
Order no.: 51504304
- Four-relay card with current input  
(standard version / CSA version)  
Order no.: 51504305

## 10 Technical data

### General data

Product designation	OUM 223 OUM 253
---------------------	--------------------

### Function and system design

Measuring principle	A sensor OUS 31 or OUS 41 is connected to the transmitter OUM 223 / 253 using the digital sensor interface. The sensors supply a standardised signal for the turbidity values and the temperature value.
---------------------	--

### Input

Measured variables	Turbidity, Solids content, Temperature
--------------------	--

#### Turbidity measurement with OUS 31

Measuring range	0.000 ... 9999 FNU, 0.00 ... 3000 ppm, 0.0 ... 3.0 g/l, 0.0 ... 200.0 %
Turbidity offset range	±99.99 FNU, ±99.99 ppm, ±99.9 g/l, ±99.9 %

#### Solids concentration measurement with OUS 41

Measuring range	0.00 ... 9999 FNU, 0.00 ... 9999 ppm, 0.0 ... 300.0 g/l, 0.0 ... 200.0 %
Solids concentration offset range	±99.99 FNU, ±99.99 ppm, ±99.9 g/l, ±99.9 %

#### Temperature measurement

Temperature sensor	NTC, 30 kΩ at 25 °C
Sensor measuring range	-5.0 ... +70.0 °C
Temperature offset range	±5 °C

#### Signal input for turbidity / solids concentration / temperature

Sensor interface	digital	
Maximum cable length to sensor	200 m	
Terminal cross-section	2.5 mm <sup>2</sup>	
Required conductor cross-section	OUM 223 OUM 253	0.75 mm <sup>2</sup> / AWG 18 1.50 mm <sup>2</sup> / AWG 14

#### Digital inputs 1 and 2

Voltage	10 ... 50 V
Current consumption	max. 10 mA

#### Current input

Current range	4 ... 20 mA, galvanically separated
Load	260 Ω at 20 mA (voltage drop 5.2 V)

### Output

#### Signal output for turbidity / solids concentration

Current range	0 / 4 ... 20 mA, galvanically isolated; error current 2.4 / 22 mA
Max. resolution	700 digits / mA
Load	max. 500 Ω
Transmission range	adjustable, min. Δ 0.1 FNU, Δ 0.1 ppm, Δ 1 g/l, Δ 0.1 %
Separation voltage	max. 350 V <sub>rms</sub> / 500 V DC
Overvoltage (lightning) protection	acc. to EN 61000-4-5:1995

## Output (continued)

## Signal output temperature (optional)

Current range	0 / 4 ... 20 mA, galvanically isolated
Max. resolution	700 digits / mA
Load	max. 500 $\Omega$
Transfer range	adjustable, $\Delta$ 10 ... $\Delta$ 100 % from measuring range
Separation voltage	max. 350 V <sub>rms</sub> / 500 V DC
Overvoltage (lightning) protection	acc. to EN 61000-4-5:1995

## Auxiliary voltage output

Output voltage	15 V $\pm$ 0.6 V
Output current	max. 10 mA

## Contact outputs (potential-free changeover contacts)

Switching current with ohmic load ( $\cos \varphi = 1$ )	max. 2 A
Switching current with ohmic load ( $\cos \varphi = 0.4$ )	max. 2 A
Switching voltage	max. 250 V AC, 30 V DC
Switching power with ohmic load ( $\cos \varphi = 1$ )	max. 500 VA AC, 60 W DC
Switching power with inductive load ( $\cos \varphi = 0.4$ )	max. 500 VA AC, 60 W DC

## Limit contactor

Pickup / dropout delay	0 ... 7200 s
------------------------	--------------

## Controller

Function (adjustable)	Pulse length / pulse frequency controller
Controller response	P, PI, PD, PID
Controller gain $K_p$	0,01 ... 20.00
Integral action time $T_n$	0.0 ... 999.9 min
Derivative action time $T_v$	0.0 ... 999.9 min
Period for pulse length controller	0.5 ... 999.9 s
Frequency for pulse frequency controller	60 ... 180 min <sup>-1</sup>
Basic load	0 ... 40% of max. set value

## Alarm

Function (switchable)	Steady / fleeting contact
Alarm delay	0 ... 2000 s (min)

**Accuracy**

**Turbidity measurement with OUS 31**

Measured value resolution	0.001 FNU, 0.01 ppm, 0.01 g/l, 0.01 %
Display deviation <sup>1</sup>	±2 % of measured value (at least 0.02 FNU)
Repeatability <sup>1</sup>	±1 % of measured value (at least 0.01 FNU)
Measurement deviation <sup>1</sup> turbidity signal output	1 % of current output range (at least 0.02 FNU)

**Solids content measurement with OUS 41**

Measured value resolution	0.01 FNU, 0.01 ppm, 0.01 g/l, 0.01 %
Display deviation <sup>1</sup>	±2 % of measured value (at least 0.02 FNU)
Repeatability <sup>1</sup>	±1 % of measured value (at least 0.01 FNU)
Measurement deviation <sup>1</sup> , solids concentration signal output	1 % of current output range (at least 0.02 FNU)

**Temperature measurement**

Measured value resolution	0,1 °C
Display deviation <sup>1</sup>	max. 1.0 % of measuring range
Measurement deviation <sup>1</sup> temperature signal output	max. 1.25% of current output range

**Ambient conditions**

Ambient temperature (nominal operating conditions)	-10 ... +55 °C
Ambient temperature (limit operating conditions)	-20 ... +60 °C
Storage and transportation temperature	-25 ... +65 °C
Relative humidity (nominal operating conditions)	10 ... 95 %, non-condensing
Ingress protection of panel-mounted instrument	IP 54 (front panel), IP 30 (enclosure)
Ingress protection of field instrument	IP 65
Pollution degree	2 acc. to IEC 61010-1
Installation category	II
Maximum altitude	2000 m above sea level
Electromagnetic compatibility	Interference emission and immunity acc. to EN 61326: 1997/ A1: 1998

**Mechanical construction**

Dimensions of panel-mounted instrument (H x W x D)	96 x 96 x 139 mm
Installation depth	approx. 165 mm
Dimensions of field instrument (H x W x D)	247 x 170 x 115 mm
Weight of panel-mounted unit	max. 0.7 kg
Weight of field instrument	max. 2.3 kg
Measured value display	LC display, 2-line, 5- and 9-digit with status displays

**Materials**

Housing of panel-mounted unit	Polycarbonate
Front membrane	Polyester, UV-resistant
Field housing    standard version CSA GP version	ABS PC Fr Polycarbonate

**Power supply**

Supply voltage	100 / 115 / 230 V AC +10 / -15 %, 48 ... 62 Hz 24 V AC/DC +20 / -15 %
Power consumption	max. 7.5 VA
Mains fuse	Microfuse, medium slow 250 V / 3.15 A

<sup>1</sup>According to IEC 746-1, for nominal operating conditions

Subject to modifications.



# 11 Appendix

Function group <b>OFFSET</b> V	Enter absolute value current measured value V1	Enter offset V2	Calibration status is displayed o.k. E--- V3	Store offset yes; no; new V4		
Function group <b>SLOPE</b> V	Enter absolute value current measured value N1	Enter slope 1.000 0.200 ... 5.000 N2	Calibration status is displayed o.k. E--- N3	Store slope yes; no; new N4		
	Calibration selection Data = calibration data; only C1 (6) is available for data set 1 C1 (6)	Display of cal. point 1 Comparative value C161	Display of cal. point 2 Comparative value C162	Display of cal. point 3 Comparative value C163	Display of slope 1 current value C164	Display of slope 2 current value C165
	1-pt = 1-point calibration C1 (5)	Entry of current calibration value current measured value entire measuring range C151	Calibration status is displayed o.k. E--- C152	Store calibration results yes; no; new C153		
	Refl = reflection adaptation C1 (4)	Entry of correct measured value 0; 0 ... 2.0 FNU 0; 0 ... 5.0 ppm (mg/l) C141	Calibration status is displayed o.k. E--- C142	Store calibration results yes; no; new C143		
	Edit = edit calibration C1 (3)	Entry of concentration of first calibration solution current value in C111 entire measuring range C131	Entry of concentration of second cal. solution current value in C112 > value in C131 x 11 C132	Entry of concentration of third calibration solution current value in C113 > value in C132 x 1.1 C133	Calibration status is displayed o.k. E--- C134	Store calibration result yes; non; new C135
	Corr = 3-point correction C1 (2)	Entry of correct concentration of calibration solution 3 current value in C113 entire meas. range C121	Calibration status is displayed o.k. E--- C122	Store calibration results yes; no; new C123		
	3-pt = 3-point calibration C1 (1)	Entry of concentration of first calibration solution 100.0 FNU; 100.0 ppm (mg/l); 10.0 g/l; 10.0 % C111	Entry of concentration to second cal. solution last calibration value C112 > C111 x 1.1 C112	Entry of concentration of third calibration solution last calibration value C113 > C112 x 1.1 C113	Calibration status is displayed o.k. E--- C114	Store calibration result yes; non; new C115
Function group <b>CALIBRATION</b> C						
	MEAS. VALUE DISPLAY with TEMPERATURE DISPLAY in °C	Temperature display in °F	Temperature display suppressed	Measured value display Current input in FNU	Measured value display Current input in %	Measured value display Current input in mA
		1st error is displayed (if present)	Other errors are displayed (up to 10 errors)			
Function group <b>SETUP 1</b> A	Selection of oper. mode FNU; ppm; mg/l; g/l; %; spec. A1	Selection of unit displayed (if A1=spec) kg/l; t/m <sup>3</sup> %; none A2	Display format selection (if A1=spec) XX.xx; X.xxx; XXX.x; XXXX A3	Display of sensor connected CUS 31; CUS 41 A4	Entry of damping (1=no damping) 10 1-60 A5	
Function group <b>SETUP 2</b> B	Switch wiper control on or off off on B1	Set duration of wiper operation 30 3 ... 999 s B2	Set pause time between wiper cycles 120 min 1 ... 7200 min B3	Selection of calibration data set used 3 1 ... 3 B4	Copy data sets no 1 → 2; 1 → 3 2 → 3; 3 → 2 B5	Display of measured value with reflection adaptation yes; no B6
Function group <b>CURRENT INPUT</b> Z	Cont. switch-off by current input Off; Input Z1	Delay for cont. switch-off current input 0 s 0 ... 2000 s Z2	Delay for cont. switch-on current input 0 s 0 ... 2000 s Z3	Switch-off limit value for current input 50% 0 ... 100% Z4	Switch-off direction for current input Low; High Z5	Feedforward control to PID controller Off; lin = linear Z6
Function group <b>CURRENT OUTPUT</b> O	Select current output Out 1; Out 2 O1	Select measured variable for 2nd current output °C; NTU; Contr O2	Characteristic selection Tab = table O3 (3)  sim = simulation O3 (2)  lin = linear O3 (1)	Select table options read edit O331	Set number of table value pairs 1 1 ... 10 O332	Selection of table value pairs 1 1 ... number of table value pairs; assign O333
			Entry of simulation value current value 0 ... 22.00 mA O321	Current range selection 4-20 mA; 0-20 mA O311	Enter 0/4-mA value 0.0 NTU; 0.0 FNU; 0.0 ppm (mg/l); 0.0 g/l; 0.0 kg/l; 0.0 t/m <sup>3</sup> 0.0 %; 0.0 °C O312	Enter 20-mA value 9999 NTU; 10.00 FNU; 9999 ppm (mg/l); 300.0 g/l; 99.99 kg/l 99.99 t/m <sup>3</sup> 10.0 %; 100.0 °C O313

Display of conversion factor current value C166
---

Entry of correct process temperature current meas. value -5.0 ... 100.0°C B7	Entry of temperature difference (offset) current offset -5.0...5.0°C B8	Entry of gas bubble barrier 3.0% 0.1 ... 100% B9
---	--	---

Feedforward control = 1 at 50% 0 ... 100% Z7
---

Entry of x value (meas. value) 0.000 NTU FNU / g/l / % O334	Entry of y value (current value) 4.00 mA 0.0 ... 20.0 mA O235	Table status o.k. yes; no O236
--	--	--------------------------------------

Field for customer settings



Activate error current for previously set error no; yes <b>F7</b>	Automatic start of cleaning function no; yes (not always displayed, see error messages) <b>F8</b>	Select "next error" or return to menu next=next error ←R <b>F9</b>		
Set max. perm. period for lower limit exceeded 60 min 0 ... 2000 min <b>P7</b>	Enter setpoint 0.000 NTU 0 ... 9999 NTU <b>P8</b>			
Entry of post-rinse time 20 s 0 ... 999 s <b>R255</b>	Number of repeat cycles 0 0 ... 5 <b>R256</b>	Set interval between two cleaning cycles (pause time) 360 min 1 ... 7200 min <b>R257</b>	Set minimum pause time 120 min 1 ... R357 min <b>R258</b>	Number of cleaning cycles without cleaning agents 0 0 ... 9 <b>R259</b>

Entry of derivate action time Tv 0.0 min 0.0...999.9 min <b>R235</b>	Selection of controller characteristic dir = direct inv = inverted <b>R236</b>	Selection len = pulse length freq = pulse frequency curr = current output 2 <b>R237</b>	Entry of pulse interval 10.0 s 0.5...999.9 s <b>R238</b>	Entry of max. pulse frequency 120 1/min 60 ... 180 1/min <b>R239</b>	Entry of minimum ON time L <sub>1</sub> 0.3 s 0.1 ... 5.0 s <b>R2310</b>	Enter basic load 40% 0 ... 40% <b>R2311</b>
--	--	--	--	--	--	---

Dropout delay setting 0 s 0 ... 2000 s <b>R225</b>	Setting of alarm threshold (as an absolute value) 100.0 °C -5.0 ... +100.0 °C <b>R226</b>	Display of LC status MAX MIN <b>R227</b>
--	---	--

Dropout delay setting 0 s 0 ... 2000 s <b>R215</b>	Setting of alarm threshold (as an absolute value) 9999 FNU; 9999 ppm (mg/l); 300.0 g/l; 200.0 % entire measuring range <b>R216</b>	Display of LC status MAX MIN <b>R217</b>
--	---	--

Entry of concentration entire measuring range <b>K7</b>	Table status o.k. yes; no <b>K8</b>
--	--

Order number is displayed <b>S7</b>	Serial number is displayed <b>S8</b>	Reset of instrument to basic values no Sens = sensor data; Facy = factory settings <b>S9</b>	Perform instrument test no Displ = display test <b>S10</b>
--	---	---	--

## 12 Index

- I**
- 0 ..... 17, 20
  - 22 ..... 20
  - 9999 ..... 17, 20
- A**
- A-Function group ..... 24, 25
  - Access codes ..... 20
  - Accessories ..... 80, 81
  - Actuating signal outputs ..... 39
  - ALARM (F) ..... 33
  - Alarm contact ..... 23, 33
  - Alarm delay ..... 33
  - Alarm threshold ..... 42, 43
  - Assemblies ..... 80
  - Assembly of OUM 223 ..... 72
  - Assembly of OUM 253 ..... 75
  - AUTO key ..... 17
- B**
- B-Function group ..... 25, 26
  - Basic load ..... 45
- C**
- C-Function group ..... 56-60
  - Cable length ..... 14
  - Calibration ..... 53
  - CALIBRATION (C) ..... 22, 56
  - Calibration data records ..... 54
  - Calibration mode ..... 19, 22
  - CHECK (P) ..... 35
  - Chemoclean function ..... 37, 41
  - Cleaning function ..... 45
  - Cleaning time ..... 41, 46
  - Code 0 ..... 17
  - Code 22 ..... 20
  - Code 9999 ..... 17
  - Coding ..... 22
  - Coding structure ..... 22
  - Complete Installation ..... 6
  - Complete measuring system ..... 6
  - CONCENTRATION (K) ..... 22, 48
  - Concentration measurement ..... 48
  - Configure hold ..... 49
  - Connection diagram ..... 12
  - Connection examples ..... 15
  - Connections of field instrument ..... 13
  - Connections of panel-mounted instrument ..... 13
  - Contact selection ..... 33
  - Control characteristic ..... 40
  - Controller characteristic ..... 44
  - Corrective maintenance ..... 69-79
  - Corrective maintenance of OUM 223 ..... 71
  - Corrective maintenance of OUM 253 ..... 74
  - Corrective maintenance
    - of measuring system ..... 78
  - Current input ..... 27
  - CURRENT INPUT (Z) ..... 29
  - CURRENT OUTPUT (O) ..... 22, 31
  - Current output table ..... 32
  - Current outputs ..... 30
- D**
- D component ..... 44
  - Damage ..... 2
  - Declaration of conformity ..... 5
  - Definition of terms ..... 69
  - Derivative action time ..... 44
  - Diagnosis ..... 69-79
  - Dimensions ..... 7
  - Disassembly of OUM 223 ..... 72
  - Disassembly of OUM 253 ..... 75
  - Display ..... 16
  - Disposal ..... 2
  - Dropout delay ..... 42, 43
- E**
- E-Function group ..... 51
  - Economy function ..... 47
  - Electrical connection ..... 12
  - Electronics box ..... 7
  - Error codes ..... 67
  - Error current ..... 33, 34
  - Error log ..... 64
  - Extension cable CYK 8 ..... 80
  - Extension of measuring cable ..... 14
- F**
- F-Function group ..... 33, 34
  - Factory settings ..... 23
  - Freezing of outputs ..... 21
  - Function coding ..... 22
  - Function group ..... 20
  - Function of keys ..... 17
  - Fuse ..... 7
- G**
- General ..... 2, 3
  - General safety notes ..... 4
- H**
- Hardware version ..... 51
  - HART ..... 52
  - Hazards ..... 2
  - Hold dwell period ..... 41, 50
  - Hold function ..... 21
- I**
- I component ..... 44
  - I-Function group ..... 52
  - Immunity to interference ..... 5
  - Installation ..... 4, 6-15
  - Instrument configuration ..... 22-36
  - Instrument upgrade ..... 81
  - Integral action time ..... 44
  - Intended application ..... 4
  - INTERFACE (I) ..... 52
  - Interfaces ..... 63
- K**
- K-Function group ..... 48, 49
  - Kp ..... 44

- L**
- LED Display . . . . . 16
  - Limit contactor . . . . . 37, 41
  - Limit contactor for temperature . . . . . 37, 43
  - Limit contactor for turbidity measured value 37
  - Linear characteristic . . . . . 31
  - Liquid crystal display . . . . . 16
  - Locking the keypad . . . . . 17, 20
- M**
- Maintenance . . . . . 64-68
  - Management of calibration data records . . 54
  - Measurement mode . . . . . 22
  - Measuring cable . . . . . 14
  - Measuring cable connection . . . . . 14
  - Measuring system . . . . . 6
  - Menu structure . . . . . 20
  - Minimum pause time . . . . . 46, 47
  - MINUS key . . . . . 17
  - Module name . . . . . 51
  - Monitoring features . . . . . 5
  - Mounting . . . . . 8
  - Mounting examples . . . . . 10
  - Mounting of field instrument . . . . . 8
- N**
- N-Function group . . . . . 62
- O**
- O-Function group . . . . . 31, 32
  - Offset . . . . . 61
  - OFFSET (V) . . . . . 61
  - Offset mode . . . . . 22
  - ON time . . . . . 45
  - Operating concept . . . . . 19
  - Operating keys . . . . . 17
  - Operating modes . . . . . 19
  - Operation . . . . . 4, 16, 17, 18, 19, 20, 21
  - Operator interface . . . . . 16
  - Optoscope . . . . . 77
  - Order code . . . . . 3, 50
- P**
- P controller . . . . . 38
  - P(ID) controller . . . . . 37, 38
  - P-Function group . . . . . 35
  - Packaging . . . . . 2
  - Panel-mounted instrument . . . . . 11
  - Partition plate . . . . . 7
  - Pause time . . . . . 40, 46, 47
  - PCS alarm . . . . . 35
  - PD controller . . . . . 38
  - PI controller . . . . . 38
  - Pickup delay . . . . . 42, 43
  - PID controller . . . . . 38, 44
  - PLUS key . . . . . 17
  - Post mounting kit . . . . . 9
  - Post mounting on a square post . . . . . 8
  - Post mounting on cylindrical pipes . . . . . 8
  - Post-rinse time . . . . . 41, 46
  - Pre-rinse time . . . . . 41, 46
  - Probe . . . . . 53
  - Product structure . . . . . 3
  - PROFIBUS . . . . . 52
  - Programming . . . . . 20
  - Pulse frequency . . . . . 45
  - Pulse frequency modulation . . . . . 39
  - Pulse length . . . . . 45
  - Pulse length modulation . . . . . 39
- Q**
- Queries . . . . . 2
- R**
- R-Function group . . . . . 41- 46
  - REL key . . . . . 17
  - RELAY (R) . . . . . 22, 41
  - Relay contact configuration . . . . . 36, 37
  - Repeat cycles . . . . . 47
  - Replacement of processor module . . . . . 77
  - Residual concrete water . . . . . 55
  - Rest period between wiping cycles . . . . . 25
  - Rinse time . . . . . 45
  - RM junction box . . . . . 80

<b>S</b>	
S-Function group	49, 50
Safety features	5
Safety instructions	4, 5
Safety notes	4
Scope of delivery	2
Scopeware	77
Selection of error	33
Selection of language	49
Self-test	22
Sensor installation	14
Sensors	80
Serial number	51
Service	49, 69
SERVICE (S)	24, 49
SETUP 1 (A)	24
SETUP 2 (B)	24, 25
Setup mode	22
Setup-Modus	19
Shipping documents	2
Simulation	31
Slope	62
SLOPE (N)	62
Software version	51
Spare parts for OUM 223	73
Spare parts for OUM 253	76
Spare parts orders	77
Start pulse	46
start-up	4
Start-up menu	24
Storage	2
Structure of measuring cable	14
SW upgrade	50
Switch-off point of contact	42
Switch-off temperature	43
Switch-on point of contact	42
Symbols	2
Symbols used	2
System configuration	24
<b>T</b>	
Technical data	82, 83, 84
Terminal blocks	7
Termination of measuring cable	14
Timer for cleaning function	37, 40
Tn	44
Transport	2
Troubleshooting	64, 65, 66, 67, 68
Tv	44
<b>U</b>	
Universal mounting post OYY 102	9
Unlocking the keypad	17, 20
Unpacking	2
Upright post OYY 102	80
<b>V</b>	
V-Function group	61
VBM junction box	14, 80
Version TB	55
<b>W</b>	
Wall mounting	8
Weather protection cover OYY 101	8, 80
Wiper controller	25
Wiping cycle	25
<b>Z</b>	
Z-Function group	29

# Declaration of contamination

---

Dear customer,

Because of legal determinations and for the safety of our employees and operating equipment we need this "Declaration of contamination" with your signature before your order can be handled. Please put the completely filled in declaration to the instrument and to the shipping documents in any case. Add also safety sheets and/or specific handling instructions if necessary.

type of instrument / sensor: \_\_\_\_\_ serial number: \_\_\_\_\_  
medium / concentration: \_\_\_\_\_ temperature: \_\_\_\_\_ pressure: \_\_\_\_\_  
cleaned with: \_\_\_\_\_ conductivity: \_\_\_\_\_ viscosity: \_\_\_\_\_

## Warning hints for medium used:



radioactive



explosive



caustic



poisonous



harmful of  
health



biological  
hazardous



inflammable



safe

Please mark the appropriate warning hints.

## Reason for return:

\_\_\_\_\_  
\_\_\_\_\_

## Company data:

company: _____	contact person: _____
_____	_____
_____	department: _____
address: _____	phone number: _____
_____	Fax/E-Mail: _____
_____	your order no.: _____

I hereby certify that the returned equipment has been cleaned and decontaminated acc. to good industrial practices and is in compliance with all regulations. This equipment poses no health or safety risks due to contamination.

\_\_\_\_\_  
(Date)

\_\_\_\_\_  
(company stamp and legally binding signature)



51512419